

ARTICLE 37.00

DEFINITIONS

Section 37.01 DEFINITIONS

For the purpose of enforcing the provisions of this Ordinance, certain terms and words used herein are defined as follows:

Section 37.01.1 **Abandonment:** To cease or discontinue a use or activity without intent to resume, but excluding temporary or short-term interruptions to a use or activity during periods of remodeling, maintaining, or otherwise improving or rearranging a facility, or during normal periods of vacation or seasonal closure.

Section 37.01.2 **Abutting:** Having property or district lines in common.

Section 37.01.3 **Accessory Use:** See USE.

Section 37.01.3-1 **Accessory Building:** A building or structure which is clearly incidental to, customarily found in connection with, subordinate to, and is located on the same zoning lot as the principal use to which it is exclusively located, which is not used or designed for the storage of motor vehicles and which does not exceed two hundred square feet. Examples of such structures include but are not limited to sheds and gazebos. The total area of the accessory building shall be deemed to include the gross floor area as defined in Section 37.01.106(a) of this Ordinance combined with the gross area of any attached covered area or extension of roof from the accessory building including but not limited to such structures as a carport, covered porch or a lean-to.

Amended May 9, 2006, by Zoning Ordinance No. 200-75

Section 37.01.4 **Adult Day-care:** See Section 37.01.263 State Licensed Facilities.

Section 37.01.5 **Adult Regulated Uses:** As used in this Ordinance, the following definitions shall apply to adult regulated uses:

FRENCHTOWN CHARTER TOWNSHIP ZONING ORDINANCE NO. 200

- Section 37.01.5(a) Adult book or supply store: An establishment having ten percent (10%) or more of all usable interior, retail, wholesale, or warehouse space devoted to the distribution, display, or storage of books, magazines, and other periodicals and/or photographs, drawings, slides, films, video tapes, recording tapes, and/or novelty items which are distinguished or characterized by their emphasis on matter depicting, describing or relating to "Specified Sexual Activities" or "Specified Anatomical Areas" (as defined herein), or an establishment with a segment or section devoted to the sale or display of such material. Such establishment or the segment or section devoted to the sale or display of such material in an establishment is customarily not open to the public generally, but only to one or more classes of the public, excluding any minor by reason of age.
- Section 37.01.5(b) Group "a" cabaret: An establishment which features any of the following: topless dancers and/or bottomless dancers, go-go dancers, strippers, male and/or female impersonators or similar entertainers, or topless and/or bottomless wait persons or employees.
- Section 37.01.5(c) Adult motion picture theater or adult live stage performing: An enclosed building used for presenting material distinguished or characterized by an emphasis on matter depicting, describing or relating to "Specified Sexual Activities" or "Specified Anatomical Areas" (as defined herein), for observation by patrons therein. Such establishment customarily not open to the public generally, but only to one or more classes of the public, excluding any minor by reason of age.
- Section 37.01.5(d) Adult massage parlor or massage establishment: A place where manipulated massage or manipulated exercises are practiced for pay upon the human body by anyone using mechanical, therapeutic, or bathing devices or techniques, other than the following: a duly licensed physician, osteopath, or chiropractor; a registered or practical nurse operating under a physician's directions; or, registered physical or occupational therapists or speech pathologists who treat patients referred by a licensed physician and operate only under supervision and physician's direction. A massage establishment may include, but is not limited to, establishments commonly known as massage parlors,

FRENCHTOWN CHARTER TOWNSHIP ZONING ORDINANCE NO. 200

health spas, sauna baths, Turkish bathhouses, and steam baths. Massage establishments, as defined herein, shall not include properly-licensed hospitals, medical clinics, or nursing homes, or beauty salons or barber shops in which massages are administered only to the scalp, the face, the neck or the shoulders.

Section 37.01.5(e) Adult outdoor motion picture theater: A drive-in theater used for presenting material distinguished or characterized by an emphasis on matter depicting, describing or relating to "Specified Sexual Activities" or "Specified Anatomical Areas" (as defined herein) for observation by patrons of the theater. Such establishment is customarily not open to the public generally, but only to one or more classes of the public, excluding any minor by reason of age.

Section 37.01.5(f) Specified anatomical areas: Portions of the human body defined as follows:

Section 37.01.5(f)(1) Less than completely and opaquely covered human genitals, pubic region, buttocks, or female breast below a point immediately above the top of the areola and

Section 37.01.5(f)(2) Human male genitals in a discernible turgid state, even if completely and opaquely covered.

Section 37.01.5(g) Specified sexual activities: The explicit display of one or more of the following:

Section 37.01.5(g)(1) Human genitals in a state of sexual stimulation or arousal.

Section 37.01.5(g)(2) Acts of human masturbation, sexual intercourse, or sodomy.

Section 37.01.5(g)(3) Fondling or other erotic touching of human genitals, pubic region, buttocks, or female breast.

Section 37.01.6 **Agriculture:** Agriculture shall mean the use of land for agricultural purposes, including farming, dairying, pasturage, nurseries, orchards, poultry farms and bona fide greenhouses operated on contiguous, neighboring or associated land as a single

FRENCHTOWN CHARTER TOWNSHIP ZONING ORDINANCE NO. 200

unit carried on by the owner-operator, manager or tenant farmer by his own labor or with assistance of members of his household or hired employees; provided, however that land to be considered a farm hereunder shall include a continuous parcel of five (5) acres or more in area.

Section 37.01.7 **Airport:** Any area of land or water designed and set aside for the landing and take-off of aircraft, including all necessary facilities for the housing and maintenance of aircraft.

Section 37.01.8 **Air Rights:** The ownership or control of all land, property, and that area of space at and above a horizontal plane over the ground surface of land used for railroad or expressway purposes. The horizontal plane shall be at a height that is reasonably necessary or legally required for the full and free use of the ground surface.

(This space left blank intentionally)

FRENCHTOWN CHARTER TOWNSHIP ZONING ORDINANCE NO. 200

- Section 37.01.9 **Alley:** Is any way not more than thirty (30) feet in width dedicated to the public and accepted by the governmental entity having jurisdiction and authority of the same and which affords a secondary means of access to abutting property, and not intended for general traffic circulation or for parking, standing, or loading.
- Section 37.01.10 **Alterations:** Any change, addition or modification in construction or type of occupancy; any change in the structural members of a building, such as bearing walls or partitions, columns, beams or girders, or any substantial change in the roof or in the interior walls or any changes in size or location of any window or door.
- Section 37.01.11 **Amusement Arcade:** A building or part of a building which five or more pinball machines, video games, or other similar player-operated devices are maintained.
- Section 37.01.12 **Amusement Park:** A parcel of land used for swimming, boating, dancing, skating, merry-go-rounds, roller coasters, theaters, arcades, fun houses, carnivals and other similar uses and their facilities, but not shooting galleries, race tracks, zoos, stables, riding academies.
- Section 37.01.13 **Animal Hospital:** See CLINIC, VETERINARY.
- Section 37.01.14 **Antenna:** (See also SATELLITE DISH ANTENNA and TOWER.) Any system of wires, poles, rods, reflecting discs, or similar devices used for the transmission or reception of electromagnetic waves external to or attached to the exterior of any building and including the supporting structure; includes, but is not limited to, amateur radio antennas, television antennas, and satellite receiving dishes.
- Section 37.01.15 **Apartment House:** An apartment house is a dwelling for three (3) or more families, living independently of each other with separate and individual kitchen, bath and toilet facilities.
- Section 37.01.16 **Apartment, Mid Rise:** An apartment building more than three (3) stories in height for housing six (6) or more families living independently of each other.
- Section 37.01.17 **Appeal:** A request or demand for a hearing or review of facts and/or actions in connection with the public enforcement of this Ordinance.

FRENCHTOWN CHARTER TOWNSHIP ZONING ORDINANCE NO. 200

(Page left blank intentionally)

FRENCHTOWN CHARTER TOWNSHIP ZONING ORDINANCE NO. 200

- Section 37.01.18 **Aquaculture:** Land devoted to the hatching, raising, and breeding of fish or other aquatic plants or animals for sale or personal use.
- Section 37.01.19 **Aquifer:** A geological unit in which porous and permeable conditions exist and thus are capable of yielding usable amounts of water.
- Section 37.01.20 **Aquifer Recharge Area:** An area that has soils and geological features that are conducive to allowing significant amounts of surface water to percolate into ground water.
- Section 37.01.21 **Automobile:** Unless specifically indicated otherwise, "automobile" shall mean any vehicle including, by way of example, cars, trucks, vans, motorcycles, and the like but shall not include commercial trucks or semi trucks and trailers.
- Section 37.01.22 **Automobile Dealership:** A building or premises used primarily for the sale of new or used automobiles and other motor vehicles.
- Section 37.01.23 **Automobile Filling Station:** A building designed or used for the retail sale of fuel (stored in underground tanks), lubricants, air, water, and other minor operating commodities for motor vehicles, and including the customary space and facilities for the installation of such commodities on or in such vehicles. Repairs of a major type are not permitted and are defined to be spray painting, body, fender, transmission, and frame repairs; major overhauling of engines requiring the removal of engine cylinder head or crankcase pan; repairs to radiators requiring the removal thereof; or complete recapping or re-treading of tires. The storage, sale or rental of mechanical equipment, on the service station site, of new or used cars, trucks, trailers, motor scooters, motor driven bicycles, motorcycles, minibikes or similar vehicles, wrecked or otherwise, shall not be considered a gasoline service station use or an accessory use to a gasoline service station. A convenience store operation shall be considered an accessory use.
- Section 37.01.24 **Automobile Repair Garage:** An enclosed building where the following services may be carried out: general repairs, engine re-building, reconditioning of motor vehicles; collision services, such as frame or fender straightening and repair; painting and undercoating of automobiles; and, similar vehicle repair activity.
- Section 37.01.25 **Automobile Wash or Car Wash Establishment:** A building or portion thereof or an area of land where automobiles are washed.

FRENCHTOWN CHARTER TOWNSHIP ZONING ORDINANCE NO. 200

- Section 37.01.26 **Automobile Wrecking Yard:** (See also JUNKYARD.) The dismantling or wrecking of used motor vehicles or trailers, or the storage, sale, or dumping of dismantled or wrecked vehicles or their parts. The presence on any lot or parcel of land of two or more motor vehicles, which, for a period exceeding 30 days, have not been capable of operating under their own power and from which parts have been or are to be removed for reuse or sale, shall constitute prima-facie evidence of an automobile wrecking yard.
- Section 37.01.27 **Bar/lounge:** See RESTAURANT.
- Section 37.01.28 **Base Flood:** The flood having a one percent chance of being equaled or exceeded in any given year. Also known as the 100-year flood.
- Section 37.01.29 **Basement:** (See also STORY, BASEMENT.) That portion of a building wholly or partly below grade, but so constructed that the vertical distance from the average grade to the basement floor is greater than the vertical distance from the average grade to the basement ceiling. A basement shall not be included as a story for height measurement, and shall not apply to earth-bermed or earth-sheltered homes.
- Section 37.01.30 **Bedroom:** A room in a dwelling unit used for or intended to be used solely for sleeping purposes by human beings.
- Section 37.01.31 **Berm:** A manmade formed earth mound of definite height and width used for obscuring or decorative purposes.
- Section 37.01.32 **Billboard:** A sign that identifies or communicates a commercial or non-commercial message related to an activity conducted, a service rendered, or a commodity sold at a location other than where the sign is located.
- Section 37.01.33 **Block:** The property bounded by a street or by a combination of streets and public lands, rights-of-way, rivers or streams, boundary lines of the Township, or any other barrier to the continuity of development.
- Section 37.01.34 **Board of Appeals:** The term Board of Appeals shall mean the Frenchtown Township, Monroe County, State of Michigan, Zoning Board of Appeals.

FRENCHTOWN CHARTER TOWNSHIP ZONING ORDINANCE NO. 200

Section 37.01.35 **Boarding or Rooming Houses:** A boarding or rooming house shall be construed to mean any dwelling occupied in any such manner that certain room in excess of those used by members of the immediate family and occupied as a home or family unit, are leased or rented to persons outside of the family, without any attempt to provide therein or therewith separate cooking for kitchen accommodations.

Section 37.01.36 **Borrow pit:** Any place or premises where dirt, soil, sand, gravel, or other material is removed below the grade of surrounding land for any purpose other than that necessary and incidental to site grading or building construction which has been approved by the Township.

Section 37.01.37 **Buffer Area:** A landscaped area intended to separate and partially obstruct the view of two adjacent land uses or properties from one another.

Section 37.01.38 **Building:** Any structure having a roof or other covering and used or built for the support, shelter or enclosure of persons, animals, chattels, or property of any kind. For the purposes of this Ordinance, all activities, uses, etc., shall be conducted within a building, unless otherwise specifically permitted by this Ordinance.

A building shall be permanently fixed to the land. A building shall not include tents, awnings, semi-trailers, or vehicles situated on a parcel. The use of tents, awnings, semi-trailers, or vehicles, situated on a parcel, for the support, shelter or enclosure of persons, animals, chattels, or property of any kind shall not be permitted. A building shall not include such structures as signs, or fences, or structures not normally accessible for human occupation, such as tanks, smokestacks, grain elevators, coalbunkers, oil cracking towers, or similar structures.

Amended July 24, 2001 by Zoning Ordinance No. 200-41.

Section 37.01.39 **Building, Accessory:** A building or structure which is clearly incidental to, customarily found in connection with, subordinate to, and is located on the same zoning lot as the principal use to which it is exclusively located, which is not used or designed for the storage of motor vehicles and which does not exceed two hundred square feet. Examples of such structures include but are not limited to sheds and gazebos. The total area of the accessory building

FRENCHTOWN CHARTER TOWNSHIP ZONING ORDINANCE NO. 200

shall be deemed to include the gross floor area as defined in Section 37.01.106(a) of this Ordinance combined with the gross area of any attached covered area or extension of roof from the accessory building including but not limited to such structures as a carport, covered porch or a lean-to.

Amended May 9, 2006, by Zoning Ordinance No. 200-75

Section 37.01.40 **Building Height:** The vertical distance measured from the established grade to:

- to the deck line of mansard roofs,
- to the average height between the eaves and the ridge for gable, hip and gambrel roofs or,
- to the highest point of the coping of a flat roof.

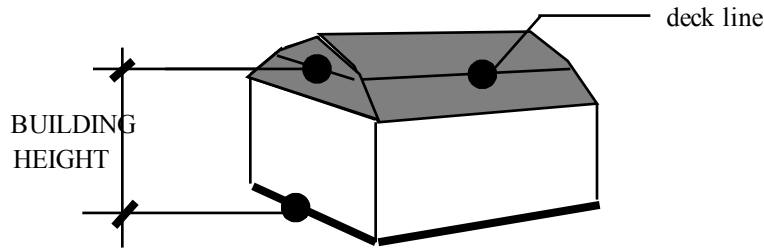

to the deck line of a mansard roof

MANSARD ROOF

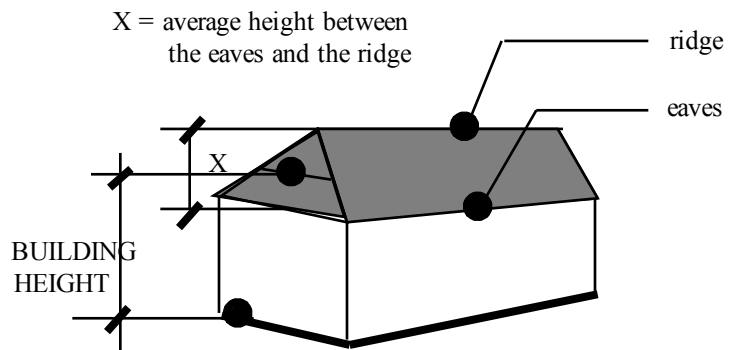

to the average height between the eaves and the ridge for a hip roof

HIP ROOF

FRENCHTOWN CHARTER TOWNSHIP ZONING ORDINANCE NO. 200

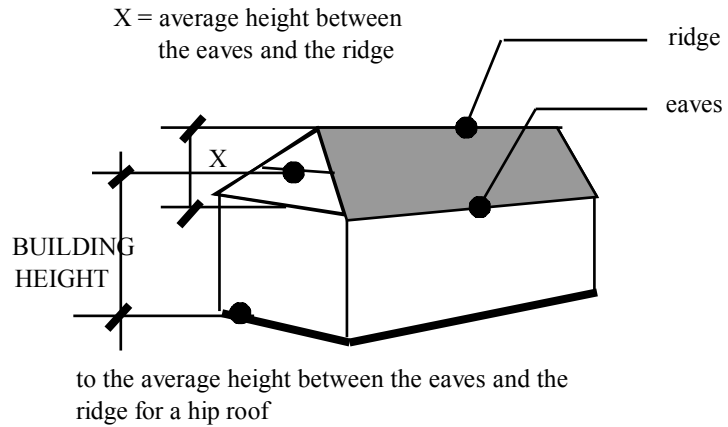

GABLE ROOF

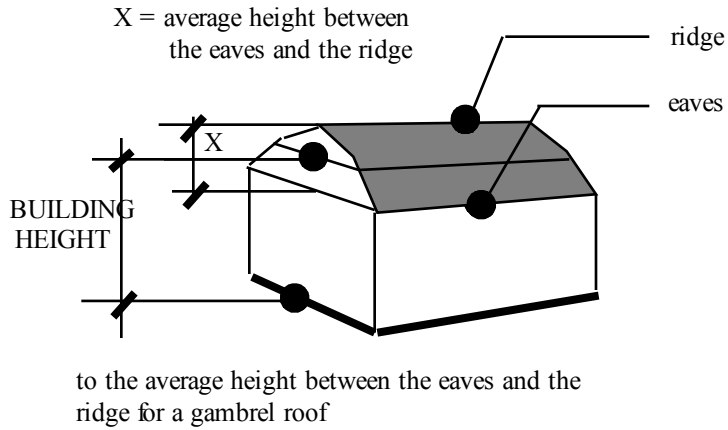

GAMBREL ROOF

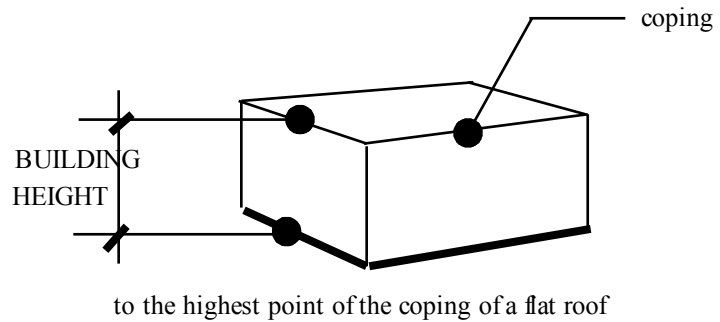

FLAT ROOF

FRENCHTOWN CHARTER TOWNSHIP ZONING ORDINANCE NO. 200

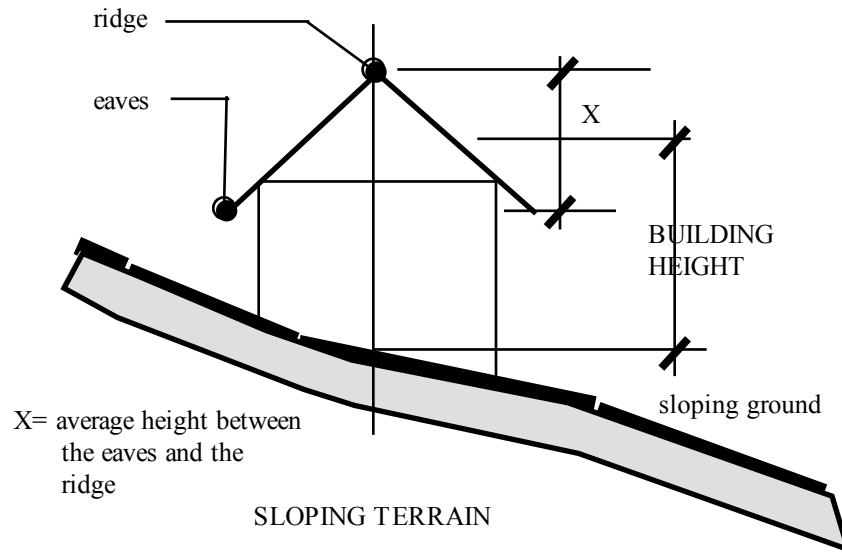

Where a building is located on sloping terrain, the height shall be measured from the average ground level at the building wall (see illustration).

Section 37.01.41 **Building Official:** This term shall refer to the Building Official of Frenchtown Charter Township, or his authorized representative.

Section 37.01.42 **Building Permits:** A building permit is the written authority issued by the Building Official of the Township permitting the construction, removal, moving, alteration, or use of a building in conformity with the provisions of this Ordinance.

Section 37.01.43 **Building Principal:** A building or, where the context so indicates, a group of buildings which are permanently affixed to the land and which are built, used, designed, or intended for the shelter or enclosure of the principal use of the parcel.

Section 37.01.44 **Building Setback Lines:** The lines which pertain to and define those minimum (building) setback lines which are established parallel to the front street or right-of-way line, rear or side property lines and within which setback area no part of a building shall project or be located, except as otherwise provided for by this Ordinance. Such line when adjacent to a building is normally formed by the junction of the outer surface of the building wall,

FRENCHTOWN CHARTER TOWNSHIP ZONING ORDINANCE NO. 200

adjoining ground. The setback then shall be measured from the outer surface of the building wall, enclosure wall or foundation. An overhang may be permitted to extend into the yard area. The overhang shall not be permitted to extend more than one (1) foot into such yard area.

Section 37.01.45 **Building Temporary:** A building which is not permanently affixed to the property, and which may be permitted to exist for a specific reason for a specific period of time. An example of a temporary building is a trailer used on a construction site.

Section 37.01.46 **Campground:** An area or tract of land on which accommodations for temporary occupancy are located or may be placed, including cabins, tents and major recreational equipment, and which is primarily used for recreational purposes and retains an open air natural character.

Section 37.01.47 **Canal:** An artificially constructed or excavated channel intended to connect two (2) bodies of water; used for navigation purposes or boat docks; and as a means of ingress or egress to other bodies of water; or for building lots on the banks thereof; shall be known as a canal and must have a minimum width of seventy-five (75) feet and a minimum depth of water at the center line of ten (10) feet. All banks must be at a minimum angle of forty-five (45) degrees and completely sodded to prevent wash or erosion thereof unless otherwise approved by the Planning Commission.

Section 37.01.48 **Caretaker Living Quarters:** An independent residential dwelling unit designed for and occupied by one (1) person or one family one of which is employed to look after goods, buildings, or property on a commercial or industrial parcel on which the living quarters are located.

Section 37.01.49 **Carnivals and Outdoor Assemblies:** A term applied to any temporary use no more than five (5) days in duration, unenclosed, whole or in part, all or any part of which includes: outdoor concerts, music festivals, rock concerts, political rallies, animal or mechanical children rides, ferris wheels, merry-go-rounds, puppet shows, games, concessions stands, or any gatherings, shows or entertainment of like character. Such carnivals and outdoor assemblies shall be considered a type of open-air business use.

Section 37.01.50 **Carport:** A partially open shelter for housing of vehicles. Such structure shall comply with all yard requirements applicable to private garages.

Section 37.01.51 **Cemetery:** Land used for the burial of the dead, including

FRENCHTOWN CHARTER TOWNSHIP ZONING ORDINANCE NO. 200

columbariums, crematories, and mausoleums.

Section 37.01.52 **Child Care Center:** Child care center or day-care center means a facility, other than a private residence, licensed pursuant to Act 116 of 1973 receiving one or more preschool or school age children for care for periods of less than 24 hours a day and where the parents or guardians are not immediately available to the child. Child care center or day-care center includes facility which provides care for not less than two consecutive weeks, regardless of the number of hours of care per day. The facility is generally described as a child care center, day-care center, day nursery, nursery school, parent cooperative preschool, play group, or drop-in center.

Section 37.01.52(a) Child care center or day-care center does not include any of the following: a Sunday school, a vacation bible school, or a religious instructional class that is conducted by a religious organization where children are in attendance for not greater than three hours per day for an indefinite period, or not greater than eight hours per day for an indefinite period, or not greater than eight hours for a period not to exceed four weeks during a twelve month period. A facility operated by a religious organization where children are cared for not greater than three hours while persons responsible for the children are attending religious services.

Section 37.01.53 **Church, Synagogue, Temple, Mosque, or Similar Religious Facility:** Any structure wherein persons regularly assemble for religious activity.

Section 37.01.54 **Clear-Cutting:** The indiscriminate removal of trees, shrubs, or undergrowth with the intention of preparing real property for nonagricultural development purposes. This definition shall not include the selective removal of non-native tree and shrub species when the soil is left relatively undisturbed; removal of dead trees; or normal mowing operations.

Section 37.01.55 **Clinic, Veterinary:** A place for the care, diagnosis, and treatment of sick or injured animals, and those in need of medical or minor surgical attention. A veterinary clinic may include customary pens or cages enclosed within the walls of the clinic building.

Section 37.01.56 **Clinic, Medical:** An establishment where human patients who are not lodged overnight are admitted for examination and treatment by a group of physicians, dentists, or similar professionals. A medical clinic may incorporate customary laboratories and

FRENCHTOWN CHARTER TOWNSHIP ZONING ORDINANCE NO. 200

patient care or major surgery.

Section 37.01.57 **Cluster Development:** A development design technique that concentrates buildings in specific areas on a site to allow the remaining land to be used for recreation, common open space, and preservation of environmentally positive or sensitive areas.

Section 37.01.58 **Commercial Use:** A commercial use relates to the use of property in connection with the purchase, sale, barter, display, or exchange of goods, wares, merchandise or personal services or the maintenance of offices or recreational or amusement enterprises, or garage, basement sales conducted on residential premises for more than six (6) calendar days during a given one-year period.

Section 37.01.59 **Commercial Vehicle:**

- All motor vehicles used for the transportation of passengers for hire, or
- constructed or used for the transportation of goods, wares or merchandise, or
- all motor vehicles designed and used for drawing other vehicles.

Section 37.01.60 **Commission:** The terms "Commission", "Planning Commission" etc. shall mean the Frenchtown Charter Township Planning Commission.

Section 37.01.61 **Community Center:** A place, structure, area, or other facility used for and providing religious, fraternal, social, and/or recreational programs generally open to the public and designed to accommodate and serve significant segments of the community.

Section 37.01.62 **Comprehensive Development Plan:** The Comprehensive Land Use Plan for the Township including graphics and written proposals indicating the general development standards and general location of streets, parks, schools, and all physical development of the Township. This shall include any unit or part of such plan and any amendment to such plan or parts thereof. Such plan or amendment may or may not be adopted by the Planning Commission and/or Board.

FEBRUARY 10, 2004

PAGE 551

ARTICLE 37.00

Section 37.01.63 **Condominium:** Ownership in common with others of a parcel of land and certain parts of a building thereon which would normally

FRENCHTOWN CHARTER TOWNSHIP ZONING ORDINANCE NO. 200

be used by all of the occupants, such as yards, foundations, basements, floors, walls, hallways, stairways, elevators and all other related common elements, together with individual ownership in fee of a particular dwelling unit in such building. Condominiums shall be subject to the regulations set forth in Michigan Public Act 59 of 1978, as amended.

Section 37.01.64 **Congregate Housing:** (See also HOUSING FOR THE ELDERLY) A residential facility for four or more elderly persons (age 60 or older) within which are provided living and sleeping facilities, meal preparation, laundry service, and room.

Section 37.01.64-1 **Conservation Easement:** An interest in land that provides a limitation on the use of land or a body of water or requires or prohibits certain acts on or with respect to the land or body of water, whether or not the interest is stated in the form of a restriction, easement, covenant, or condition in a deed, will, or other instrument executed by or on behalf of the owner of the land or body of water or in an order of taking, which interest is appropriate to retaining or maintaining the land or body of water, including improvements on the land or body of water, predominantly in its natural, scenic, or open condition, or in an agricultural, farming, open space, or forest use, or similar use or condition, as defined in Section 2140 of the Natural Resources and Environmental Protection Act, Act 451 of 1994.

Amended February 11, 2003 by Zoning Ordinance No. 200-51.

Section 37.01.65 **Convalescent or Nursing Home:** A nursing care facility, including a county medical care facility, but excluding a hospital or a facility created by Act No. 152 of the Public Acts of 1885, as amended, being Sections 36.1 to 36.12 of the Michigan Compiled Laws, that provides organized nursing care and medical treatment to 7 or more unrelated individuals suffering or recovering from illness, injury, or infirmity. Nursing home does not include a unit in a correctional facility that is operated by the department of mental health.

Section 37.01.66 **Convenience Store:** A one-story, retail store that is designed and stocked to sell primarily food, beverages, and other household supplies to customers who purchase only a relatively few items (in contrast to a "supermarket"). Convenience stores are designed to attract a large volume of stop-and-go traffic.

Section 37.01.67 **Co-op (Cooperative) Housing:** A multiple dwelling owned by a

FRENCHTOWN CHARTER TOWNSHIP ZONING ORDINANCE NO. 200

corporation which leases its units to stockholders on a proprietary lease arrangement.

Section 37.01.68 **Court:** A court is an open unoccupied space other than a yard, and bounded on at least two sides by a building. A COURT extending to the front lot line or front yard, or to a rear lot line or rear yard, is an OUTER COURT. Any other court is an INNER COURT.

Section 37.01.69 **Cul-de-sac:** A local street, one end of which is closed and consists of a circular turn around.

Section 37.01.70 **Curb Cut:** The entrance to or exit from a property provided for vehicular traffic to or from a public or private thoroughfare.

Section 37.01.71(a) **Day-care Center:** Day-care or Child Care Center means a facility, other than a private residence, licensed pursuant to Act 116 of 1973 receiving one or more preschool or school age children for care for periods of less than 24 hours a day and where the parents or guardians are not immediately available to the child. Child care center or day-care center includes facility which provides care for not less than two consecutive weeks, regardless of the number of hours of care per day. The facility is generally described as a child care center, day-care center, day nursery, nursery school, parent cooperative preschool, play group, or drop-in center.

Section 37.01.71(a)(1) Child care center or day-care center does not include any of the following: A Sunday school, a vacation bible school, or a religious instructional class that is conducted by a religious organization where children are in attendance for not greater than three hours per day for an indefinite period, or not greater than eight hours per day for an indefinite period, or not greater than eight hours for a period not to exceed four weeks during a twelve month period. A facility operated by a religious organization where children are cared for not greater than three hours while persons responsible for the children are attending religious services.

Section 37.01.71(b) **Day-care, Private Home:** Day or Child Care home means a facility, in a private residence, licensed pursuant to Act 116 of 1973 receiving one or more preschool or school age children for care for periods of less than 24 hours a day and where the parents or guardians are not immediately available to the child.

FRENCHTOWN CHARTER TOWNSHIP ZONING ORDINANCE NO. 200

of 1973, as amended, in which one (1) but less than seven (7) minor children are received for care and supervision for periods of less than 24 hours a day, unattended by a parent or legal guardian, except children related to an adult member of the family by blood, marriage, or adoption. Family day-care home includes a home that gives care to an unrelated minor child for more than 4 weeks during a calendar year.

Section 37.01.71(b)(2) Group Day-care Home: A private home licensed as a group day-care home pursuant to act No. 116 of 1973, as amended in which more than 6 but not more than 12 minor children are given care and supervision for periods of less than 24 hours a day unattended by a parent or legal guardian except children related to an adult member of the family by blood, marriage, or adoption. Group day-care home includes a home that gives care to an unrelated minor child for more than 4 weeks during a calendar year.

Section 37.01.71(b)(3) Foster Family Home: A private home in which 1 but not more than 4 minor children, who are not related to an adult member of the household by blood, marriage, or adoption, are given care and supervision for 24 hours a day, for 4 or more days a week, for 2 or more consecutive weeks, unattended by a parent or legal guardian.

Section 37.01.71(b)(4) Foster Family Group Home: A private home in which more than 4 but less than 7 minor children, who are not related to an adult member of the household by blood, marriage, or adoption, are provided care for 24 hours a day, for 4 or more days a week, for 2 or more consecutive weeks, unattended by a parent or legal guardian.

Section 37.01.72 **Density:** The number of dwelling units provided per net acre of land unless otherwise defined in this Ordinance.

FRENCHTOWN CHARTER TOWNSHIP ZONING ORDINANCE NO. 200

- Section 37.01.73 **Development:** Any man-made change to improved or unimproved real estate, including but not limited to buildings or other structures, mining, dredging, filling, grading, paving, excavation or drilling operation. The construction of a new building, reconstruction of an existing building, or improvement of a structure on a parcel or lot, the relocation of an existing building to another lot, or the improvement of open land for a new use.
- Section 37.01.74 **Distribution Center:** A use which typically involves both warehouse and office/administrative functions, where short and/or long term storage takes place in connection with the distribution operations of a wholesale or retail supply business.
- Section 37.01.75 **District Zoning:** A portion of the Township within which certain uses of land an/or buildings are permitted and within which certain regulations and requirements apply under the provisions of this Ordinance.
- Section 37.01.76 **Domestic Animals:** (See PET.)
- Section 37.01.77 **Domestic Help:** Shall mean only those persons hired by the householder for the purpose of performing domestic services and maintenance of the household.
- Section 37.01.78 **Dormitory:** A building used as group living quarters for a student body, religious order, or other group as an associated use to a college, university, boarding school, orphanage, convent, monastery, or other similar use. Dormitories do not include kitchen facilities, except a group kitchen facility to serve all residents.
- Section 37.01.79 **Drive-In Establishment:** A business establishment so developed that its principal retail or service character is totally dependent on providing a driveway approach or parking spaces for motor vehicles so as to serve patrons while in, or momentarily stepped away from, their motor vehicle (such as banks, laundry or dry-cleaning pick-up establishments).
- Section 37.01.80 **Drive-In Theater:** An open-air theater constructed and operated at an established location, without cover or roof, displaying motion pictures for the general public who view the screen or stage while seated in a vehicle. The term "drive-in theater" as used herein shall include the entire premises upon which such theater is constructed and operated, including parking areas and all other facilities accessory to such business.

FRENCHTOWN CHARTER TOWNSHIP ZONING ORDINANCE NO. 200

Section 37.01.81 **Dump:** A lot, parcel, or tract of land maintained privately or publicly for the dumping thereon of scrap wood, metal, fabric, paper and other waste materials, refuse or noxious matter.

Section 37.01.82 **Dwelling:** A house or building or portion thereof, which is occupied wholly as the home, residence or sleeping place by one (1) or more human beings, either permanently or temporarily, but in no case shall a trailer coach, automobile chassis, tent or portable building be a dwelling. In case of mixed occupancy where a building is occupied in part as a dwelling, the part so occupied shall be deemed a dwelling for the purpose of this Ordinance and shall comply with the provisions hereof relative to dwellings. Garage space, whether in an attached or detached garage, shall not be deemed a part of a dwelling for floor area requirements.

Section 37.01.82(a) **Dwelling, Accessory Apartment:** A dwelling unit that is accessory to and typically contained within a conventional single-family dwelling, and which is occupied by: (a) persons

related to the occupant of the principal residence by blood, marriage, or legal adoption, or (b) domestic servants or gratuitous guests.

Section 37.01.82(b) **Dwelling, Efficiency:** An efficiency unit is a dwelling unit consisting of one (1) room, exclusive of bathroom, kitchen, hallway, closets, or dining alcove directly off the principal room providing not less than three hundred and fifty (350) square feet of floor area.

Section 37.01.82(c) **Dwelling, Manufactured:** Is a dwelling unit which is substantially built, constructed, assembled, and finished off the premises which is intended to be located.

Section 37.01.82(d) **Dwelling, Mobile Home:** A structure, transportable in one (1) or more sections, which is built upon a chassis and designed to be used as a dwelling with or without permanent foundation, when connected to the required utilities, and includes the plumbing, heating, air-conditioning, and electrical systems contained in the structure. Recreational vehicles as described and regulated therein shall not be considered "mobile homes" for the purposes of this Ordinance.

FRENCHTOWN CHARTER TOWNSHIP ZONING ORDINANCE NO. 200

- Section 37.01.82(e) Dwelling, Multiple: A multiple dwelling is a building used for and as a residence for three (3) or more families living independently of each other and each having their own cooking and kitchen accommodations facilities therein including apartment houses, townhouses, and apartment hotels, but not including mobile homes.
- Section 37.01.82(f) Dwelling, One-Family: A detached building occupied by one (1) family and so designed and arranged as to provide living, cooking and kitchen accommodations for one (1) family only. Also known as a single-family dwelling.
- Section 37.01.82(g) Dwelling, One Family Cluster: A group of two (2) or more detached one family dwellings located on a common parcel of land held in one ownership or in condominium ownership, pursuant to the Horizontal Real Property Act, and having any yard or court in common.
- Section 37.01.82(h) Dwelling, Multiple, Townhouse: A townhouse is an attached multiple-family dwelling unit with party walls, designed as part of a series of three (3) or more dwellings, with its own front door which opens to the outdoors at ground level, its own basement, and typically, with its own utility connections and front and rear yards. Townhouses are also commonly known as row houses.
- Section 37.01.82(i) Dwelling, Seasonal: A dwelling not used for permanent residence and not occupied for more than six months in each year.
- Section 37.01.82(j) Dwelling, Site Built: Is a dwelling unit which is substantially built, constructed, assembled, and finished on the premises which is intended to serve as its final location. Site built dwelling units shall include dwelling units constructed of pre-cut materials, and panelized wall, roof and floor sections when such sections require substantial assembly and finishing on the premises which are intended to serve as its final location.
- Section 37.01.82(k) Dwelling, Two-Family: A detached two-family dwelling is that occupied by two (2) families, each provided with separate cooking and kitchen accommodations facilities for each family for living accommodations. Also known as a duplex dwelling

FRENCHTOWN CHARTER TOWNSHIP ZONING ORDINANCE NO. 200

- Section 37.01.83 **Earth- Sheltered Home:** A complete building partially below grade that is designed to conserve energy and is intended to be used as a single-family dwelling.
- Section 37.01.84 **Easement:** The right of a person, corporation, government agency, or public utility company to use public or private land owned by another for a specific purpose.
- Section 37.01.85 **Education Facility for Adult Mentally Handicapped:** An educational facility for adult mentally handicapped, operated under a current license granted by the State of Michigan, when required.
- Section 37.01.86 **Elderly Housing - Dependent:** Is a multiple-family housing form with central dining facilities provided as a basic service to each dwelling unit restricted to persons 55 years or older. Each dwelling unit may not contain cooking facilities, but must contain sanitary facilities.
- Section 37.01.87 **Elderly Housing - Independent:** Is a multiple-family housing form with full facilities for self-sufficiency in each individual dwelling unit restricted to persons 55 years or older.
- Section 37.01.88 **Emergency Shelter/Mission:** A facility providing temporary housing for one or more individuals who are otherwise homeless.
- Section 37.01.89 **Enforcement Official:** The Enforcement Official is the person or persons designated by the Township as being responsible for enforcing and administering requirements of this Zoning Ordinance. Throughout this Ordinance the Enforcement Official may be referred to as the Building Official, or their agents. Such titles do not necessarily refer to a specific individual, but rather, indicate generally the office or department most commonly associated with the administration of the regulation being referenced.
- Section 37.01.90 **Erected:** Includes built, constructed, reconstructed, moved upon, or any physical operations on the premises required for the building. Excavations, fill, drainage, and the like shall be considered a part of erection.
- Section 37.01.91 **Essential Services:** Means the erection, construction, alteration, or maintenance by public utilities or public authorities, or underground or overhead gas, electrical, steam or water transmission or distribution systems, collection, communication, supply, or disposal systems, including poles, wires, mains, drains, sewers, pipes, conduits, cables, towers, fire alarm boxes, police

FRENCHTOWN CHARTER TOWNSHIP ZONING ORDINANCE NO. 200

call boxes, traffic signals, hydrant or other similar equipment and accessories in connection therewith, as shall be reasonably necessary for the furnishing of adequate services by public utilities, or public authorities, or for the public health, safety or general welfare (not including buildings other than are primarily enclosures or shelters of the above essential service equipment which do not exceed twelve hundred (1,200) cubic feet.) Same shall be permitted as authorized by law and other ordinances, the intent here being to exempt such erection from the application of this Ordinance.

Section 37.01.92 **Excavation:** Excavation shall mean any breaking of ground, except common household gardening and ground care.

Section 37.01.93 **Exception:** Certain uses, such as essential services as defined herein, considered by the Planning Commission to be essential or desirable for the welfare of the community, and which are appropriate and not incompatible with the other uses in the zoning district, but not at every or any location or without conditions being imposed due to special considerations related to the character of the use.

Section 37.01.94 **Facade:** The exterior wall of a building exposed to public view or that wall viewed by persons not within the building.

Section 37.01.95 **Family:** One (1) or more persons related by blood, bonds of marriage, or legal adoption, plus up to a total of three (3) additional persons not so related who are either domestic servants or gratuitous guests, occupying a single dwelling unit and living as a single nonprofit housekeeping unit, or, a collective number of individuals living together in one dwelling unit, whose relationship is of a continuing non transient domestic character, and who are cooking as a single nonprofit housekeeping unit. This definition shall not include any society, club, fraternity, sorority, association, lodge, or group of students or other individuals whose domestic relationship is of a transitory or seasonal nature or for a limited duration of a school term or terms or other similar determinable period.

Section 37.01.96 **Farm:** All of the contiguous neighboring or associated land operated as a single unit on which bona fide farming is carried on directly by the owner-operator, manager or tenant farmer, by his own labor or with the assistance of members of his household or hired employees; provided, however, the land to be considered a farm hereunder shall include a continuous parcel of more than five (5) acres in area; provided further, farms may be considered as

FRENCHTOWN CHARTER TOWNSHIP ZONING ORDINANCE NO. 200

including establishments operated as bona fide greenhouses, nurseries, orchards, chicken hatcheries, poultry farms and apiaries, but establishments keeping or operating fur-bearing animals, riding, or boarding stables, commercial dog kennels, game fish hatcheries, piggeries, stockyards, stone quarries or gravel or sand pits shall not be considered a farm hereunder unless combined with a bona fide farm operations on the same continuous tract of land of not less than forty (40) acres.

A farm which is operated as a business for purposes of agricultural production is distinguished from a collection of farm buildings and animals that is operated for educational, demonstration, or recreational purposes. Such quasi-farm operations may be know as "petting zoos" or "model farm" or "interpretative farm."

Section 37.01.97 **Farm Buildings:** Any building or structure other than a dwelling, moved upon maintained, used or built on a farm which is essential to and customarily used on farms of that type for the pursuit of agricultural activities and which is used for agricultural purposes on the parcel of property on which the farm building is located. Examples of such structures include but are not limited to barns and pole barns.

Amended May 9, 2006, by Zoning Ordinance No. 200-75

Section 37.01.98 **Farm Pond:** An excavation less than two (2) ft. in depth and/or less than one thousand (1,000) square feet in area which shall be used primarily in support of agricultural pursuits permitted as part of a farm operation.

Section 37.01.99 **Feed Lot:** A feed lot shall include any of the following facilities: (1) any tract of land or structure wherein any type of fowl or the by-products thereof are raised for sale at wholesale or retail; (2) any structure, pen, or corral wherein cattle, horses, sheep, goats, or swine are maintained in close quarters for the purpose of fattening such livestock for final shipment to market.

Section 37.01.100 **Fence:** A fence may be made of wood, iron, or other material. It may be intended to or be capable of enclosing a piece of land, preventing intrusion from without, preventing straying from within, dividing one or more pieces of land, or simply to mark a boundary or property line. For the purpose of this Ordinance, any structure exceeding 12" above grade for the above use is a fence. The following shall define the specific types of fences.

FRENCHTOWN CHARTER TOWNSHIP ZONING ORDINANCE NO. 200

- Section 37.01.100(a) Fence, Decorative: A structure intended primarily for ornamental purposes. A decorative fence shall be any fence which, by definition, is not to be considered a pool fence, protective or security fence or a privacy fence or dog run or outdoor service fence.
- Section 37.01.100(b) Fence, Dog Runs and Outdoor Service Areas: A structure intended to contain an animal permitted within a single family area or to screen an outdoor service area.
- Section 37.01.100(c) Fence, Privacy Screen: A structure intended to form a visual screen or wind-break for a patio or outdoor living area located in the rear yard only.
- Section 37.01.100(d) Fence, Protective or Security: Protective or security fencing shall be considered a structure enclosing a piece of land or separating contiguous land either in whole or part serving the purpose of preventing intrusion onto or across a lot of record or any parcel or tract or unplatted land from without or straying from within.
- Section 37.01.101 **Fill, Filling:** The deposit or dumping of any matter onto or into the ground, except for common household gardening, farming, and general ground care.
- Section 37.01.102 **Flea Market:** An occasional or periodic sales activity held within a building, structure, or open area where groups of individual sellers offer goods, new and used, for sale to the public, not to include private garage sales.
- Section 37.01.103 **Floodplain:** Floodplain or flood-prone area means any land area susceptible to being inundated by water from any source.
- Section 37.01.104 **Floodway:** The channel of a river or other watercourse and those portions of the adjoining flood plains and adjacent land areas which carry and discharge the intermediate regional flood, as determined by the Federal Emergency Management Agency and as indicated on the Flood Boundary and Floodway Map.
- Section 37.01.105 **Floodway Fringe:** That portion of the 100-year floodplain located outside of the Floodway which may generally be considered as the backwater area of the 100-year floodplain. All that land in a floodplain not lying within a delineated floodway. Land within a

FRENCHTOWN CHARTER TOWNSHIP ZONING ORDINANCE NO. 200

floodway fringe which is subject to inundation by relatively low velocity flows and shallow water depths.

Section 37.01.106 Floor Area:

Section 37.01.106(a) Floor Area, Gross: The total area of a building measured by taking the outside dimensions of the building at each floor level intended for occupancy or storage.

Section 37.01.106(b) Floor Area, Usable Residential: The gross floor area minus areas in basements, unfinished attics, attached garages, and enclosed or unenclosed porches or breezeways. The total minimum floor area is set forth in the Schedule of Regulations. The minimum ground level floor area, usable residential shall be not less than six hundred (600) square feet.

Amended January 17, 2006, by Zoning Ordinance Amendment No. 200-80.

Section 37.01.106(c) Floor Area, Usable Commercial, Office and Similar Nonresidential Uses: The sum of the horizontal areas of each floor, measured from the exterior faces of the exterior walls, including all areas used for, intended to be used for, and accessible for the sale of merchandise, provision of services, or service to patrons, clients or customers. Floor area which is used for or intended to be used for the storage or processing of merchandise or for the location of utilities and which is not accessible to customer shall be excluded from the computation of Usable Floor Area. If floor plan drawings are not submitted to support the calculations usable floor area shall be defined as 80% of the gross floor area.

Section 37.01.106(d) Floor Area, Usable Industrial: The sum of the horizontal areas of each floor, measured from the exterior faces of the exterior walls, including all areas occupied by employees to carry out the industrial operations.

Section 37.01.106(e) Floor Area Ratio (FAR): The ratio between the maximum amount of floor area permitted on all floors in a building or group of buildings and the total lot site area. The total lot or site area is the "Lot Area, Net" as defined in Section 37.01.142. The following table illustrates the method of determining the max. floor area permitted based on floor area ratio.

FRENCHTOWN CHARTER TOWNSHIP ZONING ORDINANCE NO. 200

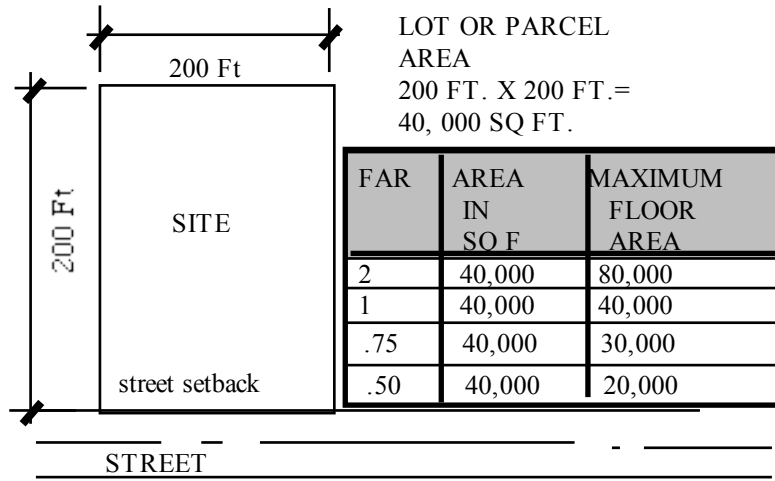

FLOOR AREA RATIO

- Section 37.01.107 **Foster Care Facility:** See STATE LICENSED RESIDENTIAL FACILITY.
- Section 37.01.108 **Foster Child:** A child unrelated to a family by blood or adoption with whom he or she lives for the purpose of care and/or education.
- Section 37.01.109 **Frontage:** The front or frontage is that side of a lot abutting on a street or way and ordinarily regarded as the front of the lot, but it shall not be considered as the ordinary side line of a corner lot.
- Section 37.01.110 **Funeral Home:** A building or part thereof used for human funeral services. Such building may contain space and facilities for: a) embalming and the performance of other services used in preparation of the dead for burial; b) the performance of autopsies and other surgical procedures; c) the storage of caskets, funeral urns, and other related vehicles, but shall not include facilities for cremation. Where a funeral home is permitted, a funeral chapel shall also be permitted.
- Section 37.01.111 **Garage:**

FRENCHTOWN CHARTER TOWNSHIP ZONING ORDINANCE NO. 200

Section 37.01.111(a) Garage, Attached: An attached garage is one in which either there is provided a common wall with the principal building for a minimum distance of eight (8) feet, or the garage is attached, by a common wall having a minimum distance of eight (8) feet, to an enclosed structural area which is part of the principal building.

Section 37.01.111(b) Garage, Private: A building or structure which is accessory to the principal use to which it is exclusively located, which is used or designed for the parking or storage of motor vehicles or watercraft owned and used by the occupants of the building to which it is accessory. Private garages may either be attached to or detached from the principal structure. Examples of such structures may include but is not limited to pavilions, boathouses and shelters for motor and recreational vehicles or watercraft. The total area of the garage shall be deemed to include the gross floor area as defined in Section 37.01.106(a) of this Ordinance combined with the gross area of any attached covered area or extension of roof from the garage including but are not limited to such structures as a carport, covered porch or a lean-to.

Amended May 9, 2006, by Zoning Ordinance No. 200-75

Section 37.01.111(c) Garage, Public: A building designed and used for the storage of automotive vehicles operated as a business enterprise with a service charge or fee being paid to the owner or operator for the parking or storage of privately owned vehicles.

Section 37.01.112 **Golf Course or Country Club:** The premises upon which the game of golf is played, including clubhouses, parking lots, swimming pools, tennis courts, or other facilities or uses customarily incidental to a golf course or country club.

Section 37.01.113 **Grade:** The term "grade" shall mean the ground elevation established for the purpose of regulating the number of stories or height of a building. The building grade shall be the level of the ground adjacent to the walls of the building if the finished grade is

FRENCHTOWN CHARTER TOWNSHIP ZONING ORDINANCE NO. 200

level. If the ground is not entirely level, the grade shall be determined by averaging the elevation of the ground for each face of the building.

Section 37.01.114 **Greenbelt:** A strip of land which is planted with trees and/or shrubs acceptable in species and caliber to the Planning Commission or other person so designated by the Commission .

Section 37.01.114-1 **Greenway:** Contiguous or linear open space, including habitats, wildlife corridors, and trails, which link parks, nature reserves, cultural features, or historic sites with each other, for recreation and/or conservation purposes.

Amended February 11, 2003 by Zoning Ordinance No. 200-51.

Section 37.01.115 **Gross Leasable Area:** The total floor area designed for tenant occupancy and exclusive use, including basements, mezzanines, and upper floors, if any, expressed in square feet and measured from outside wall surfaces.

(This space left blank intentionally)

FRENCHTOWN CHARTER TOWNSHIP ZONING ORDINANCE NO. 200

(This page left blank intentionall)

FRENCHTOWN CHARTER TOWNSHIP ZONING ORDINANCE NO. 200

Section 37.01.116 **Guest House:** An accessory building intended for temporary or periodic use as an auxiliary sleeping facility, but which does not have kitchen facilities, and is not intended to be used as a permanent residence.

Section 37.01.117 **Halfway House:** A licensed home for inmates on release from more restrictive custodial confinement or initially placed in lieu of such more restrictive custodial confinement, wherein supervision, rehabilitation, and counseling are provided to mainstream residents back into society, enabling them to live independently.

Section 37.01.118 **Hazardous Substances:** Any substance or materials that, by reason of their toxic, caustic, corrosive, abrasive or otherwise injurious properties, may be detrimental or deleterious to the health of any person handling or otherwise coming into contact with such material or substance.

Section 37.01.119 **Hazardous Uses:** All uses which involve the storage, sale, manufacture or processing of materials which are dangerous, risky and combustible and are likely to burn with moderate rapidity and/or with a considerable volume of smoke, but from which neither poisonous fumes nor explosions are to be anticipated in the event of fire.

Section 37.01.120 **Hazardous Waste:** Waste or a combination of waste and other discarded material including solid, liquid, semisolid, or contained gaseous material which because of its quantity, concentration, or physical, chemical, or infectious characteristics may cause or significantly contribute to the following if improperly treated, sorted, transported, disposed of, or otherwise managed: an increase in mortality, or

- an increase in serious irreversible illness, or
- serious incapacitating, but reversible illness, or
- substantial present or potential hazard to human health or the environment.

Section 37.01.121 **Heliport:** Any landing area used by helicopters which, in addition, includes all necessary passenger and cargo facilities, maintenance and overhaul, fueling service, storage, tie-down areas, hangars and other necessary buildings and open spaces.

FRENCHTOWN CHARTER TOWNSHIP ZONING ORDINANCE NO. 200

Section 37.01.121(a) Heliport - Unlimited Use: Any landing area used for the landing and taking off of helicopters for the purpose of picking up or discharging of passengers or cargo. No fueling, refueling, or service facilities.

Section 37.01.121(b) Heliport - Limited Use: Any landing area used for the taking off or landing of private helicopters for the purpose of picking up and discharging of passengers or cargo. This facility is not open to use by any helicopter without prior permission having been obtained.

Section 37.01.122 **Highway:** A public thoroughfare or street, except alleys, but including Federal, State, County, and Township roads and those appearing upon plats recorded in the office of the Register of Deeds for Monroe County, Michigan.

Section 37.01.123 **Historic District:** An area containing buildings or places in which historic events occurred or having special public value because of notable architectural or other features relating to the cultural or artistic heritage of the community, of such significance as to warrant conservation and preservation.

Section 37.01.124 **Home Occupation:** An occupation or profession conducted entirely within a dwelling by the inhabitants thereof, where such use is clearly incidental to the principal use of the dwelling as a residence, and where such use does not: change character or appearance of the residence, does not result in any sales of commodities or goods on the premises, and does not require equipment other than what would commonly be found on residential premises. One (1) non-illuminated nameplate, not more than two (2) square feet in area, may be attached to the building which shall contain only the name and occupation of the resident of the premises. Clinics, hospital, barber shops, nurseries, day-care centers, beauty parlors, tea rooms, veterinarian's office, tourist homes, animal hospitals, kennels, real estate offices, millinery shops, among others, shall not be deemed to be home occupations. Permitted home occupations would be clothing alteration, scissors and tool sharpening, ironing or laundering, income tax assistance, music lessons, tutoring, selling one's own painting, etc..

Section 37.01.125 **Homeowners Association:** A private, nonprofit corporation of homeowners for the purpose of owning, operating, and/or maintaining various common properties.

FRENCHTOWN CHARTER TOWNSHIP ZONING ORDINANCE NO. 200

Section 37.01.126 **Hospitals:** An institution which is licensed by the Michigan Department of Health to provide in-patient and out-patient medical and surgical services for the sick and injured, and which may include such related facilities as laboratories, medical testing services, central service facilities, and staff offices.

Section 37.01.127 **Hotel :** (See also MOTEL.). A facility offering transient lodging accommodations on a daily rate to the general public and providing additional services, such as restaurants, meeting rooms, and recreational facilities.

Section 37.01.128 **Housing for the Elderly:** An institution other than a hospital, or hotel, which provides room and board to persons fifty five (55) years of age or older. Housing for the elderly may include the following:

Section 37.01.128(a) Senior Apartments: Multiple-family dwelling units occupied by persons 55 years of age or older.

Section 37.01.128(b) Elderly Housing Complex: A building or group of buildings containing dwellings where the occupancy is restricted to persons 55 years of age or older or couples where either the husband or wife is 55 years of age or older.

Section 37.01.128(c) Congregate Housing: A type of semi-independent housing facility containing congregate kitchen, dining, and living areas, but with separate sleeping rooms. Such facilities typically provide special support services, such as transportation and limited medical care.

Section 37.01.128(d) Dependent Housing Facilities: Facilities such as nursing homes which are designed for older persons who need a wide range of health and support services, including personal nursing care.

Section 37.01.129 **Impervious Surface:** Any material that substantially reduces or prevents the infiltration of storm water into previously undeveloped land. Impervious surface shall include driveways, parking areas, sidewalks etc.

Section 37.01.130 **Industrial Park:** A planned, coordinated development of a tract of land with two or more separate industrial buildings. Such development is planned, designed, and constructed, on an integrated and coordinated basis with special attention given to on-site vehicular circulation, parking, utility needs, building design and orientation, and open space.

FRENCHTOWN CHARTER TOWNSHIP ZONING ORDINANCE NO. 200

- Section 37.01.131 **Industry, Heavy:** A use engaged in the basic processing and manufacturing of materials or products predominantly from extracted or raw materials, or a use engaged in storage of, or manufacturing processes using flammable or explosive materials, or storage or manufacturing processes that potentially involve hazardous or commonly recognized offensive conditions.
- Section 37.01.132 **Industry, Light:** A use engaged in the manufacture, predominantly from previously prepared materials, of finished products or parts, including processing, fabrication, assembly, treatment, packaging, incidental storage, sales and distribution of such products, but excluding basic industrial processing.
- Section 37.01.133 **Ingress and Egress:** As used in this Ordinance, "ingress and egress" generally is used in reference to a driveway which allows vehicles to enter or leave a parcel of property, or to a sidewalk which allows pedestrians to enter or leave a parcel of property, a building, or another location.
- Section 37.01.134 **Junk:** Any motor vehicles, machinery, appliances, products or merchandise with parts missing, or other scrap materials that are damaged, deteriorated, or are in a condition which prevents their use for the purpose for which the product was manufactured.
- Section 37.01.135 **Junkyard:** An area where waste and used or secondhand materials are bought and sold, exchanged, stored, baled, packed, disassembled, or handled, including, but not limited to: junk, scrap iron, metals, paper, rags, tires, bottles, and automobiles.
- Section 37.01.136 **Kennel:** Any lot or premises on which three (3) or more dogs are kept either permanently or temporarily boarded. All kennels shall comply with all applicable Township, County, and State regulations.
- Section 37.01.137 **Landscaping:** An improvement to the front, rear or side yards, including setback areas, which enhance the visual and architectural quality of a site. Such improvements can take the form of vegetation (trees, shrubs, ground cover, etc.) earth mound or berm, decorative fence, (a structure intended primarily for ornamental purpose and is not intended to provide protection, security, privacy or enclosure including posts or other supports, does not exceed three (3) feet in height measured from the ground) sculpture, bollard, and other visual enhancement. The Planning Commission will have the authority to determine if said improvements are to be considered landscaping in cases where a dispute may occur.

FRENCHTOWN CHARTER TOWNSHIP ZONING ORDINANCE NO. 200

Section 37.01.137A **Landscape Pond:** A Landscape Pond for the purposes of this ordinance is an excavation, container, lining or other means for holding permanent water which is 2 ft. or less in depth, has a water surface of 300 sq. ft. or less and is intended for viewing purposes only. For the purposes of this ordinance if a proposed pond is not a Farm Pond or a Landscape Pond as defined by this ordinance, it shall be considered a pond and shall be subject to the restrictions for a pond as found in the various zoning districts and Section 4.21.2.

Section 37.01.138 **Livestock:** Horses, cattle, sheep, goats, and other domestic animals normally kept or raised on a farm.

Section 37.01.139 **Loading Space, Off-Street:** An off-street space which is safely and conveniently located on the same lot as the building or buildings being served, for the temporary parking of delivery vehicles while loading and unloading merchandise and materials.

Section 37.01.140 **Lot (or Zoning Lot or Parcel):** For the purposes of enforcing this Ordinance, a lot is defined as a piece of land under single ownership and control that is at least sufficient in size to meet the minimum requirements for use, coverage, area, setbacks, and open space as required herein. A lot shall have frontage on a dedicated roadway or, if permitted by the regulations set forth herein, on a private road. A lot may consist of:

- A single lot of record.
- A portion of a lot of record.
- A combination of complete lots of record, or portion thereof.
- A piece of land described by metes and bounds.

Section 37.01.141 **Lot Area, Gross:** The net lot area plus one-half (1/2) the area of that right-of-way directly adjacent to or abutting any side of the lot, plus any portion of adjoining public lands deemed proper to be included by the Planning Commission.

Section 37.01.142 **Lot Area, Net:** The total horizontal area within the lot lines of the lot, exclusive of any abutting public street right-of-way or private road easement.

FRENCHTOWN CHARTER TOWNSHIP ZONING ORDINANCE NO. 200

Section 37.01.143 **Lot, Corner:** A lot abutting on and at the intersection of two or more streets.

Section 37.01.144 **Lot Coverage:** That part or percentage of the lot occupied by buildings or structures, including accessory building or structures.

Section 37.01.145 **Lot, Depth:** The depth of a lot is the mean horizontal distance from the center of the front street or property line to the center of the rear lot line. In the case of a lakefront lot, it shall be from the front lot line on the lake side to the street frontage line. In the case of an acreage parcel, it shall be from the front right of way line to the rear lot line.

Amended March 26, 2001 by Zoning Ordinance No. 200-48.

Section 37.01.146 **Lot, Double Frontage:** A lot other than a corner lot having frontage on two (2) more or less parallel streets. In the case of a row of double frontage lots, one (1) street will be designated as the front street for all lots in the plat and in the request for a zoning compliance permit. If there are existing buildings in the same block fronting on one or both of the streets, the required minimum front yard setback shall be observed on those streets where buildings presently front.

Section 37.01.147 **Lot, Interior:** An interior lot is a lot other than a corner with only one (1) lot line fronting on a street.

Section 37.01.148 **Lot, Lake:** A lot having frontage directly upon a lake, natural or man-made. The portion adjacent to the water shall be designated the lake frontage of the lot, and the opposite sides shall be designated the street frontage of the lot.

Section 37.01.149 **Lot Lines:** The lines bounding a lot as follows (see illustration):

Section 37.01.149(a) **Front Lot Line:** In the case of a lot not located on a corner, the front lot line is the line separating said lot from the street right of way. In the case of a corner lot or a double frontage lot, the front lot line shall be that line that separates said lot from the street which is designated as the front yard on the site plan review application or request for a building permit. In the case of a lakefront lot, the front lot line shall be that line designated as the ordinary high water mark as determined by a licensed surveyor.

FRENCHTOWN CHARTER TOWNSHIP ZONING ORDINANCE NO. 200

Amended March 26, 2001 by Zoning Ordinance No. 200-48.

Section 37.01.149(b) **Rear Lot Line:** Ordinarily, that lot line which is opposite and most distant from the front lot line. In the case of lots that are pointed at the rear, the rear lot line shall be an imaginary line parallel to the front lot line, not less than ten (10) feet in length, lying farthest from the front lot line and wholly within the lot. In any case, when this definition does not apply, the Building Official and/or the Planning Commission shall designate the rear lot line.

Section 37.01.149(c) **Side Lot Line:** Any lot line other than the front or rear lot lines. A side lot line separating a lot from a street is a side street lot line. A side lot line separating a lot from another lot or lots is an interior side lot line.

Section 37.01.150 **Lot of Record:** A lot of record is a lot the dimension and configuration of which are shown on a map recorded in the office of the Register of Deeds for Monroe County, or a lot or parcel described by metes and bounds, the accuracy of which is attested to by a Professional Engineer or Land Surveyor (so registered and licensed in the State of Michigan) and likewise so recorded and on file with the Monroe County Register of Deeds and Township Treasurer.

Section 37.01.151 **Lot Split and Consolidation:** The dividing or uniting of lots of record by virtue of changes in the deeds in the office of the Monroe County Register of Deeds and Township Treasurer.

Section 37.01.152 **Lot, Substandard:** (Also see NON CONFORMING LOT.) A lot or parcel of land that has less than the required minimum area or width as established by the zoning district in which it is located and provided that such lot or parcel was of record as a legally created lot on or before the effective date of this Ordinance.

Section 37.01.153 **Lot width** The straight line distance between the side lot lines, measured at the two points where the minimum front yard setback line intersects the side lot lines.

Section 37.01.153(a) **METHOD TO DETERMINE LOT WIDTH FOR A LOT ON A CURVED ROAD OR STREET**

FRENCHTOWN CHARTER TOWNSHIP ZONING ORDINANCE NO. 200

- A. Front yard setback measured along side lot line.
- B. Required minimum lot width
- C. Building setback measured parallel to road.

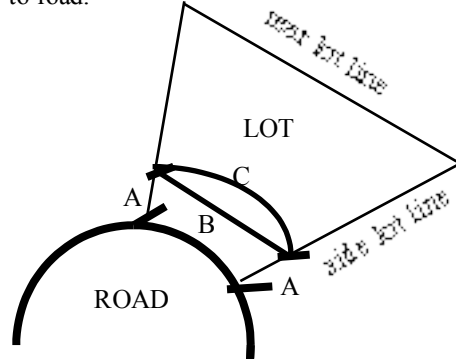

Section 37.01.154 **Main Access Drive:** Any private street designed to provide access from a public street or road to a mobile home park, apartment or condominium complex, or other private property development.

Section 37.01.155 **Major Thoroughfare:** An arterial street which is intended to serve as a large volume traffic-way for both the immediate area and the region beyond, and may be designated as a major thoroughfare, parkway, freeway, expressway or equivalent term to identify those streets comprising the basic structure of the street plan. Any street with a width, existing or proposed of one hundred twenty (120) feet shall be considered a major thoroughfare.

Section 37.01.156 **Marina:** A facility for storing, servicing, fueling, berthing, and securing and launching of private pleasure craft that may include the sale of fuel and incidental supplies for the boat owner, crews, and guests.

Section 37.01.157 **Master Land Use Plan:** The Master Land Use Plan is a document which is prepared under the guidance of the Planning Commission and consists of graphic and written materials which indicate the general location for streets, parks, schools, public buildings and all physical development of the Township.

Section 37.01.158 **Mobile Home Park:** A parcel or tract of land under the control of an individual, partnership, corporation, association or similar entity, upon which three (3) or more mobile homes are located on a continual non recreational basis and which is offered to the public for that purpose regardless of whether a charge is made therefor,

FRENCHTOWN CHARTER TOWNSHIP ZONING ORDINANCE NO. 200

together with any building, structure, enclosure, street, equipment, or facility used or intended for use incident to the occupancy of a mobile home and which is not intended for use as a temporary trailer park. Subject to conditions set forth in the Mobile Home Commission Rules and Michigan Public Act 419 of 1976, as amended.

Section 37.01.159 **Mechanical Amusement Device:** Shall mean any electronic or mechanical machine, device or contrivance which is operated by the insertion of coin, slug, token, plate, disc or the payment of a fee and is operated by the public generally for amusement only, and does not dispense any form of payoff, prize or reward. A mechanical amusement device which only provides a free game upon accumulation of a required score shall be deemed to be for amusement purposes and not prohibited herein.

Section 37.01.160 **Mezzanine:** An intermediate level or levels between the floor and ceiling of any story with an aggregate floor area of not more than one-third (1/3) of the floor area of the story in which the level or levels are located.

Section 37.01.161 **Mineral:** A naturally occurring element or combination of elements that occur in the earth in a solid state and shall include gravel, sand, clay, stone aggregate and soil.

Section 37.01.162 **Mining:** All or part of the process involved in the extraction and processing of mineral materials, but shall not include removal of gravel, sand, clay, stone aggregate and soil from a single parcel of land during any calendar year of: 1.) less than 1,000 cubic yards of materials when such removal is NOT attendant to development in accordance with an approved land balancing operation subject to the requirements of this Ordinance or pursuant to a site plan or plat which has been approved in accord with all rules and regulations of the Frenchtown Zoning Ordinance or 2.) less than 10,000 cubic yards of material when such removal is attendant to development in accordance with an approved land balancing operation subject to the requirements of this Ordinance or pursuant to a site plan or plat which has been approved in accord with all rules and regulations of the Frenchtown Zoning Ordinance.

Section 37.01.163 **Mining Reclamation Plan:** The bringing back, restoration, recovery and reconstruction of the land contained in a mining site after cessation of the mining operations to the contours, elevations and grades of the original condition of the land or to an improved condition of the land as approved by the Township Board, which will permit productive use of the land in compliance with existing zoning for the subject property or the future land use designation for the subject property as indicated on the Future Land Use Map for Frenchtown Charter Township.

FRENCHTOWN CHARTER TOWNSHIP ZONING ORDINANCE NO. 200

- Section 37.01.164 **Mining Site:** A parcel or unit of land which mining is being conducted.
- Section 37.01.165 **Mining Waste:** All accumulation of waste material and overburden placed on the land surface whether above or below water.
- Section 37.01.166 **Mini-Warehouse:** A building or group of buildings within, each of which consists of several individual storage units, each with a separate door and lock and which can be leased on an individual basis. Mini-warehouses are typically contained within a fenced, controlled-access compound.
- Section 37.01.167 **Mobile Home:** See DWELLING, MOBILE HOME.
- Section 37.01.168 **Mobile Home Site:** For the purpose of this Ordinance is a plot of ground within a mobile home park designed to accommodate and support one (1) mobile home. It is not the same as a building lot.
- Section 37.01.169 **Motel or Motor Court:** A motel or motor court is a business comprising a dwelling unit or group of dwelling units without kitchen facilities, so arranged as to furnish overnight accommodations for transient guests, not to exceed thirty (30) days continuous occupancy. Such building or group of buildings is designed, intended, or used primarily for the accommodation of automobile travelers and provides automobile parking conveniently located on the premises.
- Section 37.01.170 **Natural Features:** Natural features shall include soils, wetlands, flood plains, water bodies and channels, topography, trees and other types of vegetative cover, and geologic formations.
- Section 37.01.171 **Net Mining Operation Area:** The area stripped of overburden, that area being mined, the area used for structures and storage piles and worked-out areas which have not been reclaimed or any combination of such areas.
- Section 37.01.172 **Nightclub:** A bar, restaurant, coffee house, or similar establishment where a dance floor or entertainment is provided.
- Section 37.01.173 **Non-Conforming Building:** A building or portion thereof that was lawfully in existence at the effective date of this Ordinance, or amendments thereto, and which does not now conform to the provisions of the Ordinance in the zoning district in which it is located.

FRENCHTOWN CHARTER TOWNSHIP ZONING ORDINANCE NO. 200

- Section 37.01.174 **Non-Conforming Lot:** A lot which was lawfully in existence at the effective date of this Ordinance, or amendments thereto, and which does not now conform to the lot size, lot width, or other regulations pertaining to lots in the zoning district in which it is located.
- Section 37.01.175 **Non-Conforming Use:** See USE.
- Section 37.01.176 **Nude Modeling Studio:** A nude modeling studio is an establishment used for business and exhibiting persons in the nude acting as models for other persons to paint, photograph or draw.
- Section 37.01.177 **Nuisance:** Any offensive, annoying, or disrupting practice or object, which prevents the free use of one's property, or which renders its ordinary use or physical occupation uncomfortable. Nuisance commonly involves continuous or recurrent acts which give offense to the senses, violates the laws of decency, obstructs reasonable and comfortable use of property, or endangers life and health.
- Section 37.01.178 **Nursing Home:** means a nursing care facility, including a county medical care facility, but excluding a hospital or a facility created by Act No. 152 of the Public Acts of 1885, as amended, being Sections 36.1 to 36.12 of the Michigan Compiled Laws, that provides organized nursing care and medical treatment to 7 or more unrelated individuals suffering or recovering from illness, injury, or infirmity. Nursing home does not include a unit in a correctional facility that is operated by the department of mental health.
- Section 37.01.179 **Nursery School:** A center other than a private home where one (1) or more children are received for care and supervision. Pre-schools and nurseries are included in this definition.
- Section 37.01.180 **Nursery, Plant Material:** A space, building, and/or structure, or combination thereof, where live trees, shrubs, and other plants used for gardening and landscaping are propagated, stored, and/or offered for sale on the premises.
- Section 37.01.181 **Occupancy, Change Of:** The term "change of occupancy" shall mean a discontinue of an existing use and the substitution of a use of a different kind of class, or, the expansion of a use.

FRENCHTOWN CHARTER TOWNSHIP ZONING ORDINANCE NO. 200

- Section 37.01.182 **Occupancy Load:** The number of individuals normally occupying the building or part thereof, or for which the existing facilities have been designed.
- Section 37.01.183 **Occupied:** Used in any way at the time in question.
- Section 37.01.184 **Off-Street Parking Lot:** A facility providing vehicular parking spaces along with adequate drives and aisles for maneuvering so as to provide access for entrance and exit for the parking of more than four (4) vehicles.
- Section 37.01.185 **Office:** A building or portion of a building wherein services are performed involving predominantly administrative, professional, or clerical operations.
- Section 37.01.186 **Office Park:** A large tract of land that has been planned, developed, and operated as an integrated facility for a number of separate office buildings and supporting ancillary uses with special attention given to circulation, parking, utility needs, aesthetics and compatibility.
- Section 37.01.187 **Oil and Gas Treatment and Processing Plant:** A facility designed to separate and recover hydrocarbons (e.g., butane, ethane, propane) and/or to remove impurities (e.g., hydrogen sulfide) from oil or gas.
- Section 37.01.188 **Open Air Business:** Any business that is conducted primarily out-of-doors. Unless otherwise specified herein, open air business shall include:
- Section 37.01.188(a) Retail sales of garden supplies and equipment, including but not limited to: trees, shrubbery, plants, flowers, seed, topsoil, trellises, and lawn furniture.
 - Section 37.01.188(b) Retail sales of fruit and vegetables.
 - Section 37.01.188(c) Tennis courts, archery courts, shuffleboard, horseshoe courts, miniature golf, golf driving range, children's amusement park and/or similar recreation uses.
 - Section 37.01.188(d) Outdoor display and sale of garages, swimming pools, motor homes, mobile homes, snowmobiles, farm implements, and similar products.
 - Section 37.01.188(e) Bicycle, utility truck or trailer, motor vehicle, boats or home equipment sale; rental or repair services.

FRENCHTOWN CHARTER TOWNSHIP ZONING ORDINANCE NO. 200

Section 37.01.188(f) The retail and wholesale and/or displaying and offering for sale of all types of goods, wares, and merchandise, except when sold or displayed for sale within an enclosed building.

Section 37.01.189 **Open Space:** An area that is intended to provide light and air, and is designed for either environmental, scenic, or recreational purposes. Open space may include, but is not limited to, lawns, decorative planting, walkways, active and passive recreation areas, playgrounds, fountains, swimming pools, wooded areas, and water courses. Open space shall not be deemed to include driveways, parking lots, or other surfaces designed or intended for vehicular travel.

Section 37.01.189-1 **Open Space Preservation Area:** Natural state preserving natural resources, natural features, or scenic or wooded conditions, agricultural use; or similar use or condition. Such land does not include a golf course but may include a recreational trail, picnic area, children's play area, greenway, or linear park. Land may be, but is not required to be, dedicated to the public.

Amended February 11, 2003 by Zoning Ordinance No. 200-51.

Section 37.01.190 **Operator, Mining:** Any person, firm, corporation or agency either public or private engaged or who has applied for a permit to engage in mining, whether individually, jointly or through subsidiaries, agents, employees or any person, firm, corporation or agency engaged in managing or controlling a mining operation.

Section 37.01.190-1 **Ordinary High Water Mark:** The legal boundary separating state controlled bottomlands from private property. The ordinary high water mark shall be as determined by the Natural Resources Environmental Protection Act 451 of 1994 Paragraph No. 325 as amended that being for Lake Erie at an elevation of 571.6 feet above sea level International Great Lakes Datum (IGLD) of 1955 and 572.2 above sea level IGLD of 1985. When the soil, configuration of the surface, or vegetation has been altered by human activity, the ordinary high water mark is located where it would have been if the alteration had not occurred.

Amended February 9, 2010 by Zoning Ordinance No. 200-102.

Section 37.01.191 **Outdoor Storage:** The keeping, in an unroofed area, of any goods, junk, material, merchandise, or vehicles in the same place for more than twenty four (24) hours.

FRENCHTOWN CHARTER TOWNSHIP ZONING ORDINANCE NO. 200

- Section 37.01.192 **Outlot:** A parcel of land which is designated as an "outlot" on the recorded plat, and which is usually not intended to be used for the same purposes as other lots in the plat.
- Section 37.01.193 **Overburden:** Any substance, material, mineral or fill such as garbage, rubbish, ashes, slag, construction materials, etc., in combination or separately which forms the stratum between the existing surface of the land and the mineral being mined. It may vary from a thin layer to a mass of great depth.
- Section 37.01.194 **Par-3 Golf Course:** A golf course consisting of shortened fairways, typically no longer than two-hundred (200) yards. 18-hole, par-3 golf courses typically occupy fifty (50) to sixty (60) acres.
- Section 37.01.194-1 **Parallel Plan:** A plan utilized to compute the density permitted on any given lot or parcel. Such plan is designed according to all of the applicable provisions of the zoning district in which such lot or parcel is located as well as all of the applicable provisions of the Subdivision Control Ordinance and Zoning Ordinance regarding single family site condominiums.

Amended February 11, 2003 by Zoning Ordinance No. 200-51.

- Section 37.01.195 **Parcel:** See LOT.
- Section 37.01.196 **Park:** Any public or private land available for recreational, educational, cultural, or aesthetic use.
- Section 37.01.196(a) **County Park:** A parcel of land that is used as a park and is operated under the supervision of the County of Monroe.
- Section 37.01.196(b) **Municipal Park:** A parcel of land that is used as a park and is operated under the supervision of the Charter Township of Frenchtown.
- Section 37.01.196(c) **Private Park:** A parcel of land for use as a recreation area, play area, picnic area, or nature area, without commercial trade
- Section 37.01.196(d) **State Park :** A parcel of land that is used as a park and is operated under the supervision of the State of Michigan.

FRENCHTOWN CHARTER TOWNSHIP ZONING ORDINANCE NO. 200

- Section 37.01.197 **Parking Space:** An area of definite length and width designated for parking an automobile or other vehicle, and which is fully accessible for such purposes. A parking space is intended to permit persons to leave their automobile for a temporary period to utilize a facility.
- Section 37.01.198 **Performance Guarantee:** Any security accepted by the Township in the form of cash, certified check, performance bond, surety bond, letter of credit, or certificate of deposit endorsed to the Township to ensure that all improvements, facilities, or work required by this Ordinance will be completed in compliance with the Ordinance, regulations, and the approved plans and specifications of a development.
- Section 37.01.199 **Permit, Mobile Home Park:** This term shall mean a written permit issued by the Building Official permitting the construction, alteration or enlargement of a Mobile Home Park, subject to all applicable provisions of this Ordinance and all other applicable local, State and Federal regulations.
- Section 37.01.200 **Person:** An individual, trustee, executor, other fiduciary, corporation, firm, partnership, association, organization, or other legal entity acting as a unit.
- Section 37.01.201 **Pet:** A domesticated dog, cat, bird, gerbil, hamster, guinea pig, turtle, fish, rabbit, or other animal that is commonly available and is kept for pleasure or companionship.
- Section 37.01.202 **Photocopy Service:** A business that reproduces drawings, plans, maps, or other copy by means of blueprinting or photocopying.
- Section 37.01.203 **Piggery:** Any lot, parcel or tract of land on which hogs are kept, raised and fed on garbage or other refuse; same considered a nuisance because of offensive odors therefrom.
- Section 37.01.204 **Planned Development:** A planned development may include such concepts as, planned unit development, community unit development, planned residential development, community and other terminology denoting special zoning requirements and review procedures. These requirements and procedures are intended to provide design and regulatory flexibility, so as to accomplish the objectives of this Ordinance using innovative and effective planning approaches. The development of land that is under unified control and is planned and developed as a whole in a single development operation or programmed series of development stages. The development may include streets, circulation ways, utilities, buildings, open spaces, and other site

FRENCHTOWN CHARTER TOWNSHIP ZONING ORDINANCE NO. 200

features and improvements.

Section 37.01.205 **Planning Commission:** The Planning Commission of the Charter Township of Frenchtown.

Section 37.01.206 **Plant Nursery:** Any land used to raise trees, shrubs, flowers, and other plants for sale or for transplanting.

Section 37.01.207 **Planting Strip:** A planting strip for the purpose of this Ordinance shall consist of a combination of "natural" plant material such as ground cover, deciduous and/or evergreen shrubs, deciduous and/or evergreen trees, and/or deciduous small ornamental trees.

Section 37.01.208 **Porch, Enclosed:** A covered entrance to a building or structure which is totally enclosed, and projects out from the main wall of said building or structure and has a separate roof or an integral roof with the principal building or structure to which it is attached.

Section 37.01.209 **Porch, Open:** A covered entrance to a building or structure which is unenclosed except for columns supporting the porch roof, and project out from the main wall of said building or structure and has a separate roof or an integral roof with the principal building or structure to which it is attached.

Section 37.01.210 **Property Line:** (See also LOT LINE.) The line separating a piece of property from the street right-of-way and the lines separating a parcel of property from the parcels next to it.

Section 37.01.211 **Public Use:** Public use shall mean a use operated by a public body, said use having the purpose of serving the public health, safety, or general welfare and including uses such as public schools, parks, playgrounds, hospitals and administrative and service facilities.

Section 37.01.212 **Public Utility:** Any person, firm, corporation, municipal department, or board, duly authorized to furnish to the public under government regulations any of the following: electricity, gas, steam, communication services, cable television services, transportation services, water, sewer services, or sewage treatment.

Section 37.01.213 **Quarry Excavation:** Shall mean any breaking of the ground to hollow out by cutting or digging or removing any soil matter, except common household gardening and general farm care.

Section 37.01.214 **Railroad Classification Yard:** A railroad yard area used solely for classifying railroad freight cars into train loads, to be delivered

FRENCHTOWN CHARTER TOWNSHIP ZONING ORDINANCE NO. 200

to distant railroad centers for disbursement, or the receiving of train loads for disbursements to local centers.

Section 37.01.215 **Recreational Vehicle:** "Recreational Vehicles" shall include the following:

Section 37.01.215(a) **Travel Trailer:** A portable vehicle on a chassis, not exceeding thirty-six (36) feet in length or nine (9) feet in width, which is designed to be used as a temporary dwelling during travel, recreational, and vacation uses, and which may be identified as a "travel trailer" by the manufacturer. Travel trailers generally contain sanitary, water, and electrical facilities.

Section 37.01.215(b) **Pickup Camper:** A structure designed to be mounted on a pickup or truck chassis with sufficient equipment to render it suitable for use as a temporary dwelling during the process of travel, recreational, and vacation uses.

Section 37.01.215(c) **Motor Home:** A recreational vehicle intended for temporary human habitation, sleeping, and/or eating, mounted upon a chassis with wheels and capable of being moved from place to place under its own power. Motor homes generally contain sanitary, water, and electrical facilities.

Section 37.01.215(d) **Folding Tent Trailer:** A canvas folding structure, mounted on wheels and designed for travel and vacation use.

Section 37.01.215(e) **Boats and Boat Trailers:** "Boats" and "boat trailers" shall include boats, floats, rafts, canoes, plus the normal equipment to transport them on the highway.

Section 37.01.215(f) **Other Recreational Equipment:** Other recreational equipment includes snowmobiles, all-terrain or special terrain vehicles, utility trailers, plus the normal equipment to transport them on the highway.

Section 37.01.216 **Recreational Vehicle (RV) Park:** Any lot of land upon which two or more recreational vehicle sites are located, established, or maintained for occupancy by recreational vehicles of the general public as temporary living quarters for recreation or vacation purposes.

Section 37.01.217 **Recycling Collection Point:** An incidental use that serves as a neighborhood or community drop-off for temporary storage of

FRENCHTOWN CHARTER TOWNSHIP ZONING ORDINANCE NO. 200

recoverable resources. No processing of such items would be allowed.

Section 37.01.218 **Recycling Plant:** A facility that is not a junkyard and in which resources, such as newspapers, magazines, books, and other paper products; glass, metal cans, and other products, are recycled, reprocessed, and treated to return such products to a condition in which they may again be used for production.

Section 37.01.219 **Recycling Transfer Plant:** A facility that is not a junkyard and in which resources, such as newspapers, magazines, books, and other paper products; glass, metal cans, and other products, are processed, treated, and prepared for shipment to a facility for recycling, reprocessing, and treatment to return such products to a condition in which they may again be used for production.

Section 37.01.220 **Research Laboratory:** A building or group of buildings in which are located facilities for scientific research, investigation, testing, or experimentation, but not facilities for the manufacture or sale of products, except as incidental to the main purpose of the laboratory.

Section 37.01.221 **Restaurant:** A restaurant is any establishment whose principal business is the sale of food and beverages to the customer in a ready-to-consume state, and whose method of operation is characteristic of a carry-out, drive-in, drive-through, fast food, standard restaurant, or bar/lounge, or combination thereof, as defined below.

Section 37.01.221(a) **Restaurant, Carry-Out:** A carry-out restaurant is a restaurant whose method of operation involves sale of food, beverages, and/or frozen deserts in disposable or edible containers or wrappers in a ready-to-consume state for consumption primarily off the premises.

Section 37.01.221(b) **Restaurant, Drive-In:** A drive-in restaurant is a restaurant whose method of operation involves delivery of prepared food so as to allow its consumption in a motor vehicle or elsewhere on the premises, but outside of an enclosed building.

Section 37.01.221(c) **Restaurant, Drive-Through:** A drive-through restaurant is a restaurant whose method of operation involves the delivery of the prepared food to the customer in a motor vehicle, typically through a drive-through window, for consumption off of the premises.

FRENCHTOWN CHARTER TOWNSHIP ZONING ORDINANCE NO. 200

Section 37.01.221(d) Restaurant, Fast-Food: A fast-food restaurant is a restaurant whose method of operation involves minimum waiting for delivery of ready-to-consume food to the customer at a counter or cafeteria line for consumption at the counter where it is served, or at tables, booths, or stands inside or outside of the structure, or for consumption off the premises, but not in a motor vehicle at the site.

Section 37.01.221(e) Restaurant, Standard: A standard restaurant is a restaurant whose method of operation involves either:

Section 37.01.221(e)(1) The delivery of prepared food by waiters and waitresses to customers seated at tables within a completely enclosed building, or

Section 37.01.221(e)(2) The prepared food is acquired by customers at a cafeteria line and is subsequently consumed by the customers at tables within a completely enclosed building.

Section 37.01.221(f) Bar/Lounge: A bar or lounge is a type of restaurant which is operated primarily for the dispensing of alcoholic beverages, although the sale of prepared food or snacks may also be permitted. If a bar or lounge is part of a larger dining facility, it shall be defined as that part of the structure so designated or operated.

Section 37.01.222 **Retaining Wall:** A permanent solid barrier of brick, stone, wood, or other opaque material approved by the Building Official intended to enclose an area. For the purpose of this Ordinance all supporting members, posts, stringers, braces, pilasters or other construction features of a retaining wall shall be located and placed on the inside of the wall away from public view. All retaining walls, moreover, shall be constructed and/or painted, tinted or colored in one (1) color only for their exterior surface, and no sign or advertising shall be placed, affixed, painted or designed thereon.

Section 37.01.223 **Road, Public:** All public property reserved or dedicated for street traffic.

Section 37.01.224 **Roadside Stands:** A roadside stand is a temporary or permanent building operated for the purpose of selling only produce raised on said premises by the proprietor of the stand or his family, and its use shall not make into a commercial district, land which would otherwise be an agricultural district, nor shall its use be deemed a

FRENCHTOWN CHARTER TOWNSHIP ZONING ORDINANCE NO. 200

commercial activity, but such stand if of a permanent character, shall not be more than one (1) story high nor larger in floor area than twenty (20) feet by twenty (20) feet and must be set back from the nearest highway right-of-way line at least thirty-five (35) feet.

Section 37.01.225 **Satellite Dish Antenna:** A round, parabolic antenna intended to receive signals from orbiting satellites and other sources.

Section 37.01.226 **Sauna or Open Bathhouse:** A sauna or open bathhouse is an establishment used for equipment and housing of apparatus wherein members of the public may have a steam bath or hot water bath.

Section 37.01.227 **School:** A facility that provides a curriculum of elementary and/or secondary academic instruction, including kindergartens, elementary schools, junior high schools, and high schools.

Section 37.01.228 **Screening:** The method by which a view of one site from another adjacent site is shielded, concealed, or hidden. Screening techniques may include fences, walls, hedges, berms, or other features.

Section 37.01.229 **Seating Capacity:** The actual seating capacity of an area based upon the number of seats or one seat per 18 inches of bench or pew length. For other areas where seats are not fixed, the seating capacity shall be determined as indicated by the Building Code adopted by the Frenchtown Charter Township Board.

Section 37.01.230 **Self-Service Station:** An establishment where liquids used as motor fuels are stored and dispersed into the fuel tanks of motor vehicles by persons other than the service station attendant and may include facilities available for the sale of other retail products typically associated with this type operation.

Section 37.01.231 **Semi-Trailer:** A trailer, which may be enclosed or not enclosed, exceeding eighteen (18) feet in length, having wheels generally only at the rear, and supported in front by a truck tractor or towing vehicle.

Section 37.01.232 **Separate Ownership:** Ownership of a parcel of property wherein the owner does not own adjoining vacant property. Owner of a property may include dual or multiple ownership by a partnership, corporation, or other group. Provided, that the owner of any number of contiguous lots of record considered as a single lot of record for the purpose of this Ordinance as he so elects, and in

FRENCHTOWN CHARTER TOWNSHIP ZONING ORDINANCE NO. 200

such case the outside perimeter of said group of lots of record shall constitute the front, rear, and side lot lines thereof.

Section 37.01.233 **Service Truck:** A pick-up truck or van that is used in conjunction with a repair or maintenance business, such as a plumbing, electrical, or carpentry business.

Section 37.01.234 **Setback, Street:** Is the distance as measured from the centerline of the road to establish the front, rear and/or side lot line for the purpose of establishing yard and/or other requirements of this Ordinance.

Section 37.01.235 **Setback, Yard:** (See also YARD.) The distance between a front, side or rear lot line and the nearest supporting member of a structure on the lot. The minimum required setback is the minimum distance between a front lot line(as determined by the street setback line), the side or rear lot line and the nearest supporting member of a structure in order to conform to the required yard setback provisions of this Ordinance .

Section 37.01.235-1 **Sewage Systems:**

37.01.235-1(a): Community Onsite Sewage Treatment System: An onsite sewage treatment facility which is designed by a professional engineer licensed in the State of Michigan, and which serves more than one single-family residential dwelling. Such treatment facilities include but are not limited to, septic tanks and tile fields, recirculating sand filters and other pretreatment units such as package treatment plants. It does not include the use of lagoon systems and lagoons are expressly prohibited.

37.01.235-1(b): Public Sewerage System: A sewer system and treatment facility that is used to collect, transport, and treat domestic and industrial wastes that is owned and operated by a governmental agency. The “sewer system” means the pipes, channels, conduits, manholes, pumping stations, and appurtenances, collectively or severally, actually used or intended for use by the public for the purpose of collecting, conveying, or transporting domestic or industrial wastes to a treatment facility.

FRENCHTOWN CHARTER TOWNSHIP ZONING ORDINANCE NO. 200

37.01.235-1(c): Individual Sewage Disposal System: On-Site Sewage Disposal System: An “individual sewage disposal system” shall mean a sewage disposal system other than a public system which is under the jurisdiction of Part 41, P.A. 451, 1994, as amended, which receives human excreta, liquid wastes or both from one premise. Included within the scope of this definition are septic tank-soil absorption system, privies, chemical toilets, and such other types as may be approved by the Health Officer. (Monroe County Sanitary Code, April 2001 Edition, Section 500.09, Page 34).

Amended September 28, 2004, by Zoning Ordinance No. 200-67.

Section 37.01.236 **Shopping Center:** A grouping of retail business and service uses on a single site with common parking facilities.

Section 37.01.237 **Sidewalk Cafe:** An area adjacent to or directly in front of a street-level eating or drinking establishment located within the sidewalk area of the public right-of-way exclusively for dining, drinking, and pedestrian circulation. The encroachment area of a sidewalk cafe may be separated from the remainder of the sidewalk by railings, fencing, or landscaping planter boxes or a combination thereof.

Section 37.01.238 **Sign:** Any device using words, numerals, figures, designs, or trademarks designed to inform or attract the attention of persons not on the premises on which the sign is located, provided, however, that the following shall not be included in the application of the regulations herein .

Section 37.01.238(a) Signs not exceeding one (1) square foot in area and bearing only property numbers, post office box numbers, names of occupants of premises, or other identification of premises not having commercial connotations;

Section 37.01.238(b)Flags and insignia of any government except when displayed in connection with commercial promotion;

Section 37.01.238(c) Legal notices; identification, informational, or directional signs erected or required by governmental bodies;

Section 37.01.238(d)Integral decorative or architectural features of buildings, except letters, trademarks, moving parts, or moving lights;

FRENCHTOWN CHARTER TOWNSHIP ZONING ORDINANCE NO. 200

- Section 37.01.238(e) Signs directing and guiding traffic and parking on private property, but bearing no advertising matter.
- Section 37.01.239 **Sign, Accessory:** A sign relating in its subject matter to the premises on which it is located, or to products, accommodations, services, or activities on the premises.
- Section 37.01.240 **Sign, Awning, Canopy or Marquee:** A sign painted, stamped, perforated, or stitched, or otherwise applied on the valance of an awning. This shall include illuminated architectural canopy signs defined in Section 37.01.241.
- Section 37.01.241 **Sign, Architectural Canopy:** An illuminated architectural canopy sign (backlit awning) is an enclosed, illuminated structure that is attached to the wall of a building with the face of the sign approximately parallel to the wall and with the message integrated into its face.
- Section 37.01.242 **Sign, Billboard:** See BILLBOARD.
- Section 37.01.243 **Sign, Electronic Message Board:** Any sign that uses changing lights to form a sign message or messages wherein the sequence of messages and the rate of change is electronically programmed and can be modified by electronic processes.
- Section 37.01.244 **Sign, Flashing:** Any sign which by method or manner of illumination, flashes on or off, winks, or blinks with varying light intensity, shows motion, or creates the illusion of motion or revolves in a manner to create the illusion of being on or off.
- Section 37.01.245 **Sign, Free Standing:** A sign supported by one or more upright poles, columns, or braces placed in or on the ground and not attached to any building or structure.
- Section 37.01.246 **Sign, Illuminated:** A sign illuminated in any manner by an artificial light source.
- Section 37.01.247 **Sign, Interior:** Any sign temporarily affixed to or displayed on the interior of an establishment so as to be readable from the exterior.

FRENCHTOWN CHARTER TOWNSHIP ZONING ORDINANCE NO. 200

- Section 37.01.248 **Sign, Number:** For the purpose of determining the permitted number of sign, a sign shall be considered to be a single display surface or display device containing elements organized, related, and composed to form a unit. Where matter is displayed in a random manner without organized relationship of elements, or where there is reasonable doubt about the relationship of elements, each element shall be considered to be a single sign.
- Section 37.01.249 **Sign, Off-Premises:** See BILLBOARD.
- Section 37.01.250 **Sign, Portable:** Any sign not permanently affixed to the ground or to a building, including any sign attached to or displayed on a vehicle that is used for the expressed purpose of advertising a business establishment, product, service, or entertainment, when that vehicle is so parked as to attract the attention of the motoring or pedestrian traffic.
- Section 37.01.251 **Sign, Projecting:** Any sign other than a wall sign that is attached to and projects from the wall or face of a building or structure, including an arcade/marquee sign.
- Section 37.01.252 **Sign, Roof:** Any sign erected upon, against, or directly above a roof or roof eaves, or on top or above the parapet, or on a functional architectural appendage above the roof or roof eaves.
- Section 37.01.253 **Sign, Surface Area:** The entire area within a circle, triangle or parallelogram enclosing the extreme limits of writing, representation, emblem or any figure of similar character, together with any frame or other material or color forming an integral part of the display or used to differentiate the sign from the background against which it is placed; excluding the necessary supports or uprights on which such sign is placed. Where a sign has two or more faces, the area of all faces shall be included in determining the area of the sign, except that where two such faces are placed back to back and are at no point more than two feet from one another, the area of the sign shall be taken as the area of one face if the two faces are of equal area, or as the area of the larger face if the two faces are of unequal area.
- Section 37.01.254 **Sign, Temporary:** A display, informational sign, banner, or other advertising device constructed of cloth, canvas, fabric, wood, or other temporary material, with or without a structural frame, and intended for a limited period of display, including decorative displays for holidays or public demonstrations.
- Section 37.01.255 **Sign, Wall/Exterior:** A sign painted on the outside of a building or attached to, and erected parallel to the face of a building and supported throughout its length by such building.

FRENCHTOWN CHARTER TOWNSHIP ZONING ORDINANCE NO. 200

- Section 37.01.256 **Sign, Window:** A sign painted, stenciled, or affixed on a window, which is visible from the exterior of the building.
- Section 37.01.257 **Site Plan:** A plan, prepared to scale, showing accurately and with complete dimensions, the boundaries of a site and the location of all buildings, structures, uses, and principal site development features proposed for a specific parcel of land.
- Section 37.01.258 **Sludge:** Any matter or sediment that is precipitated by treatment of sewage at any type of sewage treatment facility, or at any other place.
- Section 37.01.259 **Snowmobile:** Any motorized vehicle designed to travel primarily on snow or ice, steered by means of wheels, skis or runners.
- Section 37.01.260 **Soil Removal:** Shall mean removal of any kind of soil or earth matter, including topsoil, sand, gravel, clay or similar materials, or combination thereof, except common household gardening and general farm care.
- Section 37.01.261 **Stable, Private:** An accessory building for the keeping of horses or other similar large domestic animals, other than dogs and cats, for the sole use of the residents of the principal use, which shall not include the keeping of domestic animals for others, or for commercial boarding.
- Section 37.01.262 **Stable, Public:** A public stable is an enclosed building for housing, for the keeping of horses or other large domestic animals, in which any such animals are kept for remuneration, hire, or sale.
- Section 37.01.263 **State Licensed Residential Facility:** Any structure constructed for residential purposes that is licensed by the State of Michigan pursuant to Public Act 287 of 1972, Public Act 116 of 1973, or Public Act 218 of 1979. These acts provide for the following types of residential structures:
- Section 37.01.263(a) State Licensed Residential Facility for Six or Less Persons: means a structure constructed for residential purposed that is licensed by the State of Michigan pursuant to Act 218 of 1979 of Act 116 of 1973 which provides resident services for 6 or less persons under 24-hour supervision or care for persons in need of that supervision or care.

FRENCHTOWN CHARTER TOWNSHIP ZONING ORDINANCE NO. 200

Section 37.01.263(b) Adult Foster Care Facility: Means a governmental or non governmental establishment that provides foster care to adults. Adult foster care facility includes facilities and foster care family homes for adults who are aged, mentally ill, developmentally disabled, or physically handicapped who require supervision on an ongoing basis but who do not require continuous nursing care. Adult foster care facility does not include any of the following:

- Section 37.01.263(b)(1) A nursing home licensed under Article 17 of the public health code, Act No. 368 of the Public Acts of 1978, as amended, being Sections 333.20101 to 333.22260 of the Michigan Compiled Laws.
- Section 37.01.263(b)(2) A home for the aged licensed under Article 17 of the public health code, Act No. 368 of the Public Acts of 1978, as amended.
- Section 37.01.263(b)(3) A hospital licensed under Article 17 of the public health code, Act No. 368 of the Public Acts of 1978, as amended.
- Section 37.01.263(b)(4) A hospital for the mentally ill or a facility for the developmentally disabled operated by the department of mental health under the mental health code, Act No. 258 of Public Acts of 1974, as amended, being Sections 330.1001 to 330. 2106 of the Michigan Compiled Laws.
- Section 37.01.263(b)(5) A county infirmary operated by a county department of social services under Section 55 of the social welfare act, Act No. 280 of the Public Acts of 1939 , as amended, being Section 400.55 of the Michigan Compiled Laws.
- Section 37.01.263(b)(6) A child caring institution, children's camp, foster family home, or foster family group home licensed or approved under Act No. 116 of the Public Acts of 1973, as amended, being Sections 722.111 to 722.128 of the Michigan Compiled Laws, if the number of

FRENCHTOWN CHARTER TOWNSHIP ZONING ORDINANCE NO. 200

residents who become 18 years of age while residing in the institution, camp, or home does not exceed the following:

- (i) Two , if the total number of residents is 10 or fewer.
- (ii) Three, if the total number of residents is not less than 11 and not more than 14.
- (iii) Four, if the total number of residents is not less than 15 and not more than 20.
- (iv) Five, if the total number of residents is 21 or more.

Section 37.01.263(b)(7) A foster family home licensed or approved under Act No. 116 of the Public Acts of 1973, being Sections 722.111 to 722.128 of the Michigan compiled Laws, that has a person who is 18 years of age or older placed in the foster family home under Section 5(7) of Act No. 116 of the Public Acts of 1973, being Section 722.115 of the Michigan compiled Laws.

Section 37.01.263(b)(8) As establishment commonly described as an alcohol or a substance abuse rehabilitation center, a residential facility for persons released from or assigned to adult correctional institutions, a maternity home, or a hotel or rooming house that does not provide or offer to provide foster care.

Section 37.01.263(b)(9) A facility created by Act No. 152 of the Public Acts of 1885, as amended, being Sections 36.1 to 36.12 of the Michigan Compiled Laws.

FRENCHTOWN CHARTER TOWNSHIP ZONING ORDINANCE NO. 200

Section 37.01.263(c) **Adult Foster Care Family Home:** means a private residence licensed as an Adult Foster Care Family Home pursuant to Act 218 of 1979, as amended with the approved capacity to receive 6 or fewer adults to be provided with foster care for 5 or more days a week and for 2 or more consecutive weeks. The adult foster care family home licensee shall be a member of the household and an occupant of the residence.

Section 37.01.263(d) **Adult Foster Care Small Group Home:** means an adult foster care facility licensed as an Adult Foster Care Small Group

Home pursuant to Act 218 of 1979, as amended with the approved capacity to receive 12 or fewer adults to be provided with foster care.

Section 37.01.263(e) **Adult Foster Care Large Group Home:** means an Adult Foster Care Large Group Home facility licensed as an Adult Foster Care Large Group Home pursuant to Act 218 of 1979, as amended the approved capacity to receive at least 13 but not more than 20 adults to be provided with foster care.

Section 37.01.263(f) **Congregate Facility:** See Section 37.01.64

Section 37.01.264 **Storage Space/Automobile:** A storage space is intended to be used to place or leave an automobile for preservation or later pickup or disposal.

Section 37.01.265 **Story (Storey):** That portion of a building, other than a basement or mezzanine as defined herein, included between the upper surface of any floor and the upper surface of the floor or roof next above it.

Section 37.01.265(a) **Basement:** That portion of a building wholly or partly below grade, but so constructed that the vertical distance from the average grade to the basement floor is greater than the vertical distance from the average grade to the basement ceiling. A basement shall not be included as a story for height measurement.

Section 37.01.265(b) **Mezzanine:** A mezzanine shall be deemed a full story when it covers more than one-third (1/3) of the area of the story underneath said mezzanine, or, if the vertical distance from the floor next below the mezzanine to the floor next above it is twenty-four (24) feet or more.

Section 37.01.265(c) Story-Half: A half story is an uppermost story lying between the uppermost floor and the roof, the useable floor area of which does not exceed fifty (50%) percent of the floor area of the story immediately below it and which contains not less than two hundred (200) square feet of livable floor area with a clear ceiling height of not less than seven (7) feet, six (6) inches (7' 6").

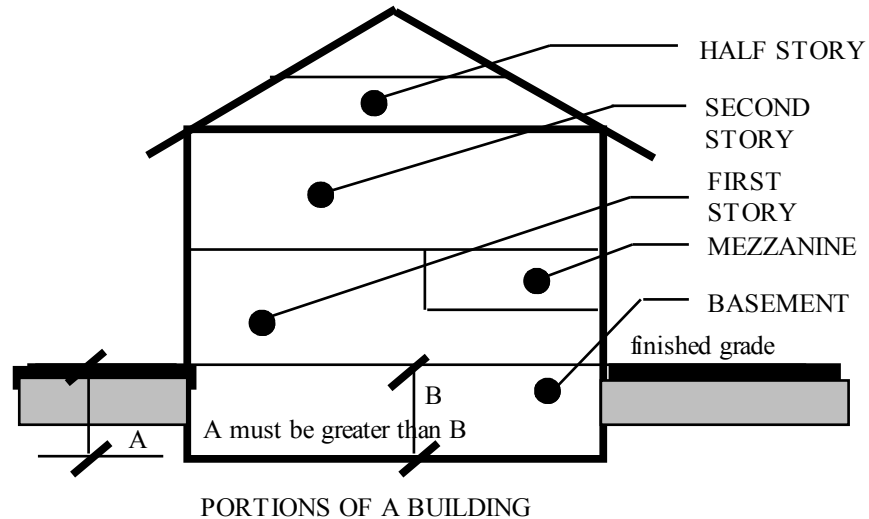

Section 37.01.266 **Street:** A public or private thoroughfare intended primarily to provide vehicular circulation and access to abutting property.

Section 37.01.267 **Street, Expressways:** Expressways are limited access interregional arterial routes (superhighways). They are designed exclusively for unrestricted movement, have no private access, and intersect only with selected arterial highways or major streets by means of interchanges engineered for free-flowing movement.

Section 37.01.268 **Street, Local or Minor Street:** A street whose sole function is to provide access to abutting properties.

Section 37.01.269 **Street, Private Street or Road:** A street or road under private ownership which has been constructed for the purposes of providing access to adjoining property, and which is normally open to the public so that persons other than the occupants of adjoining property may travel thereon.

Section 37.01.270 **Structure:** Anything constructed or erected, the use of which requires location on the ground or attachment to something having location on the ground. Structures include, but are not limited to, principal and accessory buildings, towers, decks, fences, privacy screens, walls and signs.

FRENCHTOWN CHARTER TOWNSHIP ZONING ORDINANCE NO. 200

Section 37.01.271 **Swimming Pool:** The term "swimming pool" shall mean any structure or container located either above or below grade designed to hold water to a depth of greater than twenty-four (24) inches, intended for swimming or bathing. A swimming pool shall be considered as an accessory building for the purpose of determining required yard spaces and maximum lot coverage.

Section 37.01.272 **Temporary Building or Use:** A temporary building or use shall mean a building or use permitted to exist during periods of construction of the principal building or use, or for special events.

Section 37.01.273 **Tents:** Tents as used in this Ordinance shall mean a shelter or canvas or the like supported by poles and fastened by cords or pegs driven into the ground and shall not include those types of tents solely for children's recreational purposes.

Section 37.01.274 **Theater:** A building, room, or outdoor structure for the presentation of performances or motion pictures. For the purposes of this Ordinance, the following distinctions between various types of theaters shall apply:

Section 37.01.274(a) **Motion Picture Theater:** An enclosed building used for presenting motion pictures which are observed by paying patrons from seats situated within the building.

Section 37.01.274(b) **Outdoor Theater:** A site on which a motion picture screen is constructed for presenting motion pictures which are observed by paying patrons from their own cars situated on the site.

Section 37.01.274(c) **Live Theater:** The performances of dramatic literature, comedy, musical plays etc. by live actors or performers.

Section 37.01.275 **Tourist Home:** A tourist home shall mean any dwelling occupied in such a manner that certain rooms in excess of those used by members of the family, and occupied as a dwelling unit, are rented or offered for rent to the public for compensation and catering primarily to overnight guests traveling by motor vehicle.

Section 37.01.276 **Tower:** A structure situated on a nonresidential site that is intended for transmitting or receiving television, radio, or telephone communications, excluding those exclusively for dispatch communications.

Section 37.01.277 **Township:** Frenchtown Charter Township, Monroe, Michigan .

FRENCHTOWN CHARTER TOWNSHIP ZONING ORDINANCE NO. 200

Section 37.01.278 **Township Board:** Whenever in this Ordinance appear the words "Township Board", or Board it shall mean the Township Board of Frenchtown Township.

Section 37.01.279 **Travel Trailer:** A portable vehicle unit primarily designed for travel and / or recreational use. This term also includes folding campers, truck mounted campers etc. but does not include mobile homes.

Section 37.01.280 **Travel Trailer Park:** A recreation - oriented facility for the overnight or short-term parking of travel trailers or tents. Also identified as a campground. Occupancy within the park shall not exceed twenty one (21) days within a sixty (60) day period or forty two (42) days within a twelve month period.

Section 37.01.281 **Trunk Terminal:** Land and buildings used as a relay station for the transfer of a load from one vehicle to another, one party to another. The terminal cannot be used for permanent or long term accessory storage for principal land uses at other locations. The terminal facility may include storage areas for trucks and buildings or areas for the repair of trucks associated with the terminal.

Section 37.01.281-1 **Undeveloped State:** The natural state preserving natural resources, natural features, or scenic or wooded conditions, agricultural use, open space, or a similar use or condition. Land in an undeveloped state does not include a golf course but may include a recreational trail, picnic area, children's play area, greenway, or linear park. Land in an undeveloped state may be, but is not required to be dedicated to the public.

Amended February 11, 2003 by Zoning Ordinance No. 200-51.

Section 37.01.282 **Use:** The purpose for which land or buildings thereon are designed, arranged, or intended to be occupied, or for which they are occupied or maintained.

Section 37.01.282(a) **Accessory:** A use which is clearly incidental to, serving a purpose customarily associated with and located on the same lot or lot of record as the principal use to which it is related. In no case shall such accessory use dominate, in area, extent or purpose, the principal land use or building.

FRENCHTOWN CHARTER TOWNSHIP ZONING ORDINANCE NO. 200

Section 37.01.282(b) Uses Requiring Special Conditions or Approval: A use that would not be appropriate generally or without restriction throughout the zoning district but which, if controlled as to number, area, location, or relation to the neighborhood, would not be detrimental to public health, safety, or general welfare and shall mean a use of land for which a conditional or special land use permit is required.

Section 37.01.282(c) Non-Conforming: A use which was lawfully in existence at the effective date of this Ordinance, or amendments thereto, and which does not now conform to the use regulations of the zoning district in which it is now located.

Section 37.01.282(d) Use, Permitted: A permitted use is a use which may be lawfully established in a particular district or districts provided it conforms with all requirements, regulations, and standards of such district.

Section 37.01.282(e) Use, Principal: The principal use is the main use of land and buildings and the main purpose for which land and buildings exist.

Section 37.01.283 **Utility Room:** A utility room, or space, is a room, or space, located other than in the basement, specifically designed and constructed primarily to house any home utilities such as the heating unit and laundry facilities.

Section 37.01.284 **Utility Trailer:** A small trailer that is designed to be pulled by an automobile, van or pick-up truck.

Section 37.01.285 **Variance:** A modification of the literal provision of the Zoning Ordinance granted when strict enforcement of the Zoning Ordinance would cause undue hardship owing to circumstances unique to the individual property on which the variance is granted. A variance to permit a use not otherwise permitted within a zoning district (i.e., a "use variance") shall not be permitted.

Section 37.01.285-1 **Vineyard:** A plantation of grape bearing vines, grown mainly for the off site production of wine, raisins, table grapes or non-alcoholic grape juice.

Amended May 11, 2010, by Zoning Ordinance No. 200-103.

Section 37.01.286 **Wall, Obscuring:** A structure of definite height and location to serve as an obscuring screen in carrying out the requirements of the Ordinance.

FRENCHTOWN CHARTER TOWNSHIP ZONING ORDINANCE NO. 200

Section 37.01.287 **Warehouse:** (See also DISTRIBUTION CENTER.) A building used for short and/or long term storage in connection with production and marketing or in connection with manufacturing, freight handling, and retailing.

Section 37.01.288 **Warehouse Retail Outlet:** A commercial/warehouse facility that sells to member groups on a retail basis.

Section 37.01.289 **Warehousing and Distribution:** A use engaged in storage, wholesale, and distribution of manufactured products, supplies, and equipment, but excluding bulk storage of materials that are inflammable or explosive or that create hazardous or commonly recognized offensive conditions.

Section 37.01.289-1 **Watercourse:** Any natural or artificial watercourse, stream, river, creek, ditch, channel, canal, conduit, culvert, drain, waterway, gully, ravine or wash in which water flows in a definite direction or course, either continuously or intermittently, and which has a definite channel, bed and banks, and shall include any area adjacent thereto subject to inundation by reason of overflow or floodwater.

Amended May 9, 2006, by Zoning Ordinance No. 200-75

Section 37.01.290 **Wetland:** An area that is inundated or saturated by surface water or ground water at a frequency and duration sufficient to support, and that, under normal circumstances, does support, a prevalence of vegetation typically adapted for life in saturated soil conditions, commonly known as hydrophytic vegetation.

Section 37.01.291 **Wholesale Sales:** On-premise sales of goods primarily to customers engaged in the business of reselling the goods.

Section 37.01.291-1. **Winery:** A building or property that produces wine for sale or distribution.

Amended May 11, 2010, by Zoning Ordinance No. 200-103.

Section 37.01.292 **Yard:** An open space on the same lot with a building, unoccupied and unobstructed from the ground upward, except as otherwise permitted in this Ordinance. The *minimum required setback* is the minimum depth of a front, rear or side yard necessary to conform to the required yard setback provisions of this Ordinance.

FRENCHTOWN CHARTER TOWNSHIP ZONING ORDINANCE NO. 200

Section 37.01.292(a) Yard, Front: An open space extending the full width of the lot, the depth of which is the minimum horizontal distance between the street setback line and the nearest line of the principal building. Unless otherwise specified, on corner lots there shall be maintained a front yard along each street frontage.

Section 37.01.292(b) Yard, Rear: An open space extending the full width of the lot, the depth of which shall be the minimum horizontal distance between the rear lot line and the nearest line of the principal building. On corner lots, the rear yard may be opposite either street frontage, but there shall only be one rear yard.

Section 37.01.292(c) Yard, Side: An open space between a principal building and the side lot line, extending from the front yard to the rear yard, the width of which shall be the horizontal distance from the nearest point of the side lot line to the nearest point on the principal building.

